

LS TRACTOR

SERVICE MANUAL

XP8084,8094,8101



LS Mtron

LS TRACTOR

PREFACE

This service manual is to provide servicing personnel with information for precise and quick service for **XP** tractors with high-end technologies. It contains various information on the general specifications, fundamental structure and operating principle, instructions for disassembly, assembly, inspection and adjustment, and troubleshooting on each component for easier and precise service.

This vehicle should be well-maintained and serviced properly for ultimate satisfaction of users. Therefore, it is necessary for servicing personnel to understand information in this manual thoroughly and keep it handy for service.

Most accidents during servicing are occurred by negligence on safety precautions and instructions. Therefore, servicing personnel should be fully aware of service procedures, methods, inspection points and safety precautions outlined in this manual for precise and safe service as well as ultimate satisfaction of customers.

As LS genuine parts are manufactured under the strict quality assurance system, only genuine parts should be used in this tractor to maintain its optimal condition. Mtron always put every effort into development and manufacture of quality products.

Also, information contained in this manual is subject to change without notice for quality and performance improvement of this tractor.

Keep this service manual in a safe and handy place. If there is any typo, wrong information or question for this manual, feel free to contact LS Mtron.

※ REMARKS





- **This manual does not contain information for every possible accident and precautions during service. Therefore, the tractor should be serviced only by well-trained servicing personnel with care.**
- **Using unspecified parts, including engine oil and transmission fluid, or poor-quality fuel can damage the tractor severely.**
- **Information and figures in this manual should not be copied or used without prior permission by LS Mtron.**

MEANING OF SAFETY SYMBOLS

Safety precautions outlined in this manual and information in DANGER, WARNING and CAUTION labels attached on the vehicle body should be followed strictly to avoid damage and injuries. Servicing personnel should be thoroughly aware of and follow such information and precautions.

If any of the DANGER, WARNING and CAUTION decals on the tractor is damaged or missing, have your Dealer restore it to its original location.

Information with safety symbols should be strictly followed for ultimate safety. The meaning of each symbol is as follows:

 DANGER	This indicates the potential hazards that injuries or even death can happen if no precaution is taken.
 WARNING	This indicates the most serious hazards that serious injuries or even death can happen if no precaution is taken.
 CAUTION	This indicates the potential hazards that minor injuries can happen if no precaution is taken. Also, this symbol can be used as a warning for unstable behavior.
 IMPORTANT	This indicates important work procedures and technical information for user's convenience.
 NOTES	This indicates information for user's interest and help.

※ IMPORTANT

- The safety symbols in this manual cannot indicate every possible hazard. If any hazard not specified in this manual occurs, contact your Dealer immediately.

HOW TO USE THIS MANUAL

1. TARGET READER

This manual is designed for readers who have intermediate service knowledge and technical skills for this tractor. Servicing personnel should understand instructions and information in this manual thoroughly for rapid and precise inspection and service.

2. CONTENTS

This manual is published in book form and consists of several chapters: Preface, Safety and General Information, Engine, Clutch & Transmission, Front & Rear axle, Brake System, Hydraulic System, Electric System, A/C & Heater and Index. As specifications, figures and information specified in this manual are based on the standard option vehicle, some details might be different depending on the vehicle model and type.

3. STRUCTURE

This manual is structured as follows:

TABLE OF CONTENTS

1

III CLUTCH & TRANSMISSION

2

TABLE OF CONTENTS

III-1 GENERAL INFORMATION	III-2 SERVICE
1. POWERTRAIN DIAGRAM3-5	1. SERVICE OVERVIEW3-40
2. DRIVING SPEED3-7	1.1 General precautions3-40
3. CLUTCH SECTION.....3-10	1.2 Standard component installation3-40
3.1 Specifications3-10	1.3 Basic Maintenance3-42
	1.4 Oil and fluid.....3-43

HEADER

1

III CLUTCH & TRANSMISSION

XP MODEL

6

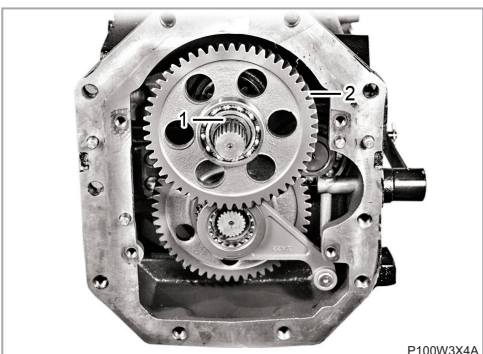

P100W3X4A

7. Pull out the snap ring (1) from the creep speed counter gear shaft and remove the creep speed counter gear (2).

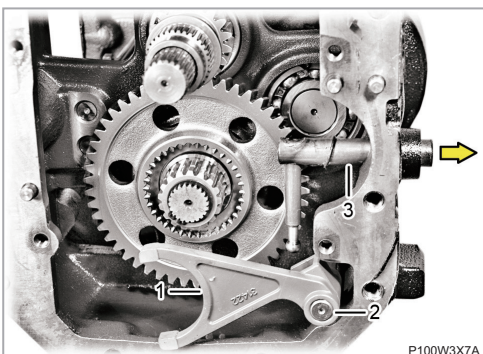

P100W3X7A

10. Remove the range shift (M-H) fork (1) and creep speed rail (2) and pull out the creep speed arm (3).

I SAFETY AND GENERAL INFORMATION

II ENGINE

III CLUTCH & TRANSMISSION

3

HOW TO USE THIS MANUAL

FOOTER

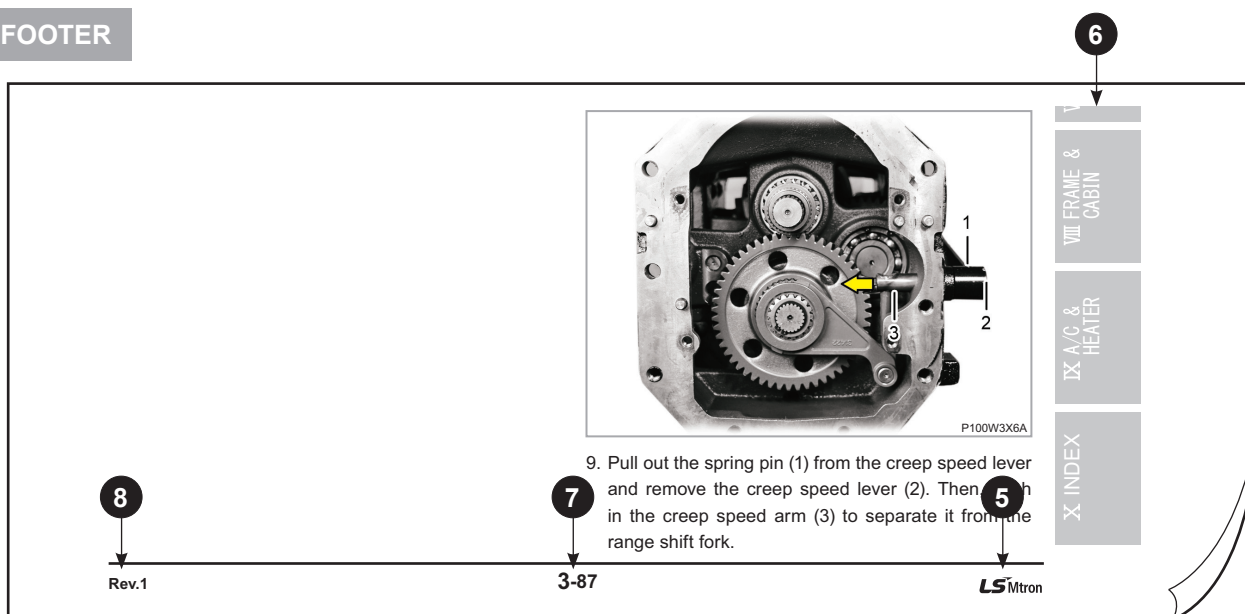

① Chapter

This section indicates the corresponding chapter, such as Safety and General Information, Engine, etc.

② Table of Contents

This section shows the corresponding sections and sub-sections. For the chapter Safety and General Information and Engine, the section number is sequentially given. For the other chapters, they are divided into two main sections: general information and service.

③ Description

Generally, description is located right below the corresponding figure. Some large figures and charts are displayed on pages without description. Each illustration is assigned with its own number and large illustration over A4 size is on A3.

④ Model

This indicates the vehicle model for this manual. Where an illustration or information applies only to certain types, this is indicated in the text.

⑤ Company logo

This is the company logo. It is on the left or the right side of its page to identify its odd or even page.

⑥ Side chapter index

This indicates chapter index. The current chapter is highlighted in a dark color while the other chapters are grayed for easy identification.

⑦ Page number

The page number is assigned as follows:

Example) 3-87: Page 87 of Chapter 3

⑧ Revision number

Indicates the number of revisions made to this manual. This number is printed on the page that reflects this revision. If a page has been revised, it is to be used in place of the page used before revision and it is not necessary to keep the old page.

4. Others

Part names referred in this manual are standardized to identify their functions efficiently and they may be different from names in other materials, such as the part list and user manual, and on the tractor's decals and labels. All illustration and pictures in this manual are based on the latest product information available at the time of publication. Therefore, some of the information in this manual may differ from the machine you have. The specifications and other information are subject to change for the purpose of improvement without notice.

TABLE OF CONTENTS

* SAFETY AND GENERAL INFORMATIO	I
* ENGINE	II
* CLUTCH & TRANSMISSION	III
* FRONT & REAR AXLE	IV
* BRAKE	V
* HYDRAULIC SYSTEM	VI
* ELECTRICAL SYSTEM	VII
* FRAME & CABIN	VIII
* A/C & HEATER.....	IX
* INDEX.....	X

I SAFETY AND GENERAL INFORMATION

TABLE OF CONTENTS

1. SAFETY TIPS.....	1-9	3.5 TIRE MAINTENANCE.....	1-24
1.1 GENERAL SAFETY TIPS.....	1-9	3.6 PRECAUTIONS FOR DISASSEMBLY	
1.2 TO AVOID PERSONAL INJURIES.....	1-10	AND ASSEMBLY.....	1-25
1.3 DURING SERVICING.....	1-11	3.6.1 PRECAUTIONS BEFORE STARTING	
1.4 ENVIRONMENT PROTECTION.....	1-14	SERVICE.....	1-25
2. SAFETY DECALS.....	1-15	3.6.2 CAUTIONS DURING ASSEMBLY.....	1-25
2.1 MOUNTING LOCATION.....	1-15	3.6.3 WIRING MATING SECTION AND	
3. GENERAL INFORMATION.....	1-18	SHEATH.....	1-27
3.1 SERIAL NUMBER.....	1-18	3.6.4 TOOL.....	1-32
3.1.1 MANUFACTURE'S SERIAL NUMBER.....	1-18	3.7 TORQUE SPECIFICATION TABLES.....	1-33
3.1.2 ENGINE NUMBER.....	1-18	3.7.1 STANDARD BOLT HARDWARE &	
3.1.3 TRANSMISSION NUMBER.....	1-18	HYDRAULIC CONNECTOR TORQUES,	
3.1.4 HOUR METER.....	1-18	SPECIFICATIONS AND INFORMATION..	1-33
3.2 EXTERNAL DIMENSIONS.....	1-19	3.7.2 UNIT CONVERSION TABLE.....	1-41
3.3 SPECIFICATIONS.....	1-21	3.8 LUBRICATING GREASE.....	1-42
3.4 OIL SPECIFICATIONS AND CAPACITY.....	1-24	3.9 MAINTENANCE SCHEDULE CHART.....	1-43

1. SAFETY TIPS

1.1 GENERAL SAFETY TIPS

Extra attention is needed and the following safety precautions should be strictly followed in your work place for service.

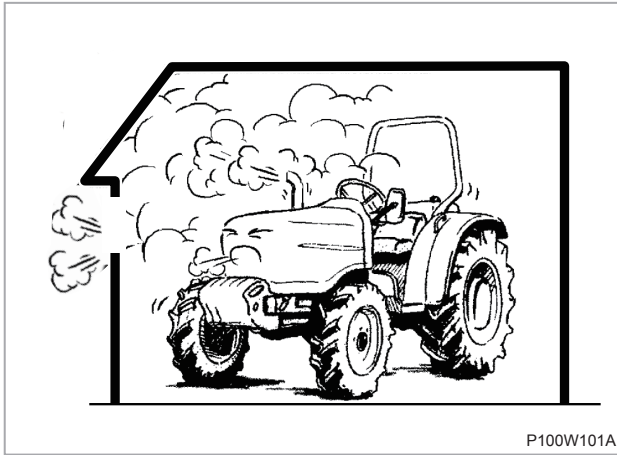

P100W101A

1. Keep your work place and surroundings clean and well-ventilated.

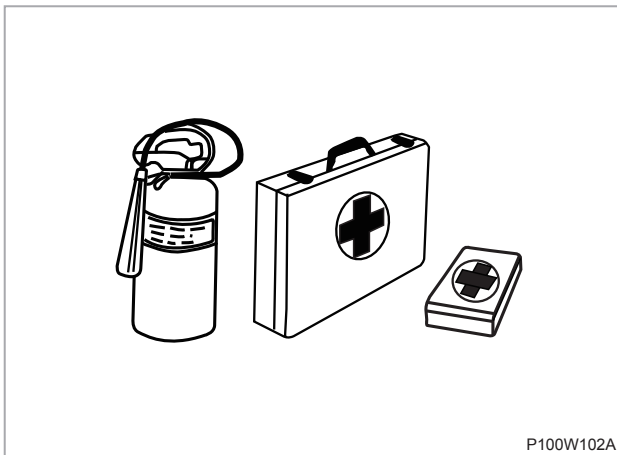

P100W102A

2. Keep an emergency kit and appropriate hygiene equipments handy in your workshop.
3. Keep a fire extinguisher handy in your workshop. Have your fire extinguisher checked regularly and have yourself well informed on its use.



P100W104A

4. Mark the safety symbols and signs for clear view in emergency.

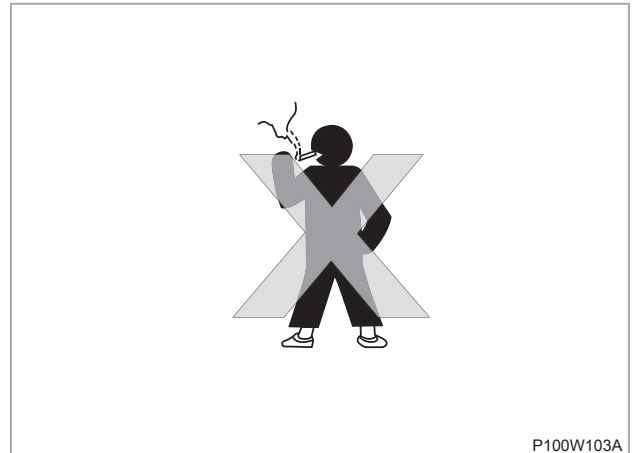

P100W103A

5. Never smoke in the workshop to avoid fire.

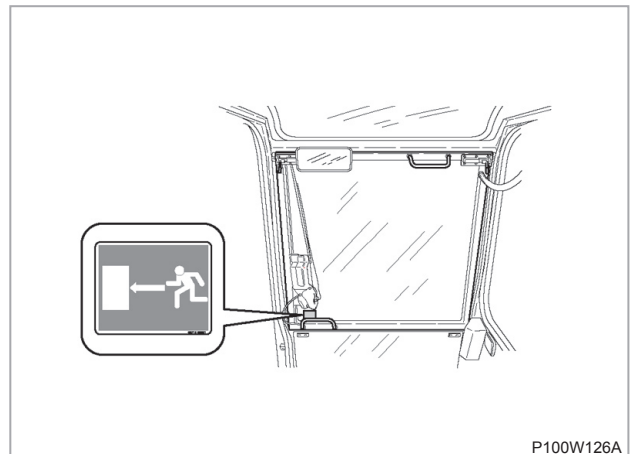

P100W126A

6. There should be an emergency exit and its sign for evacuation in emergency.

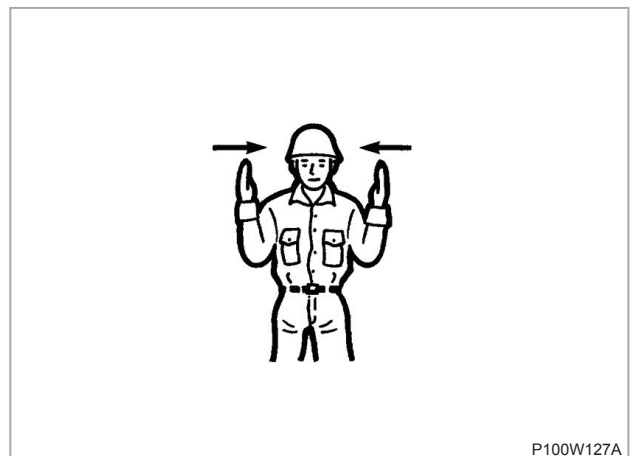

P100W127A

7. Follow helper's guidance for a special service.