

GROOMING MOWERS FMR- SERIES FMR 48-60-72-84

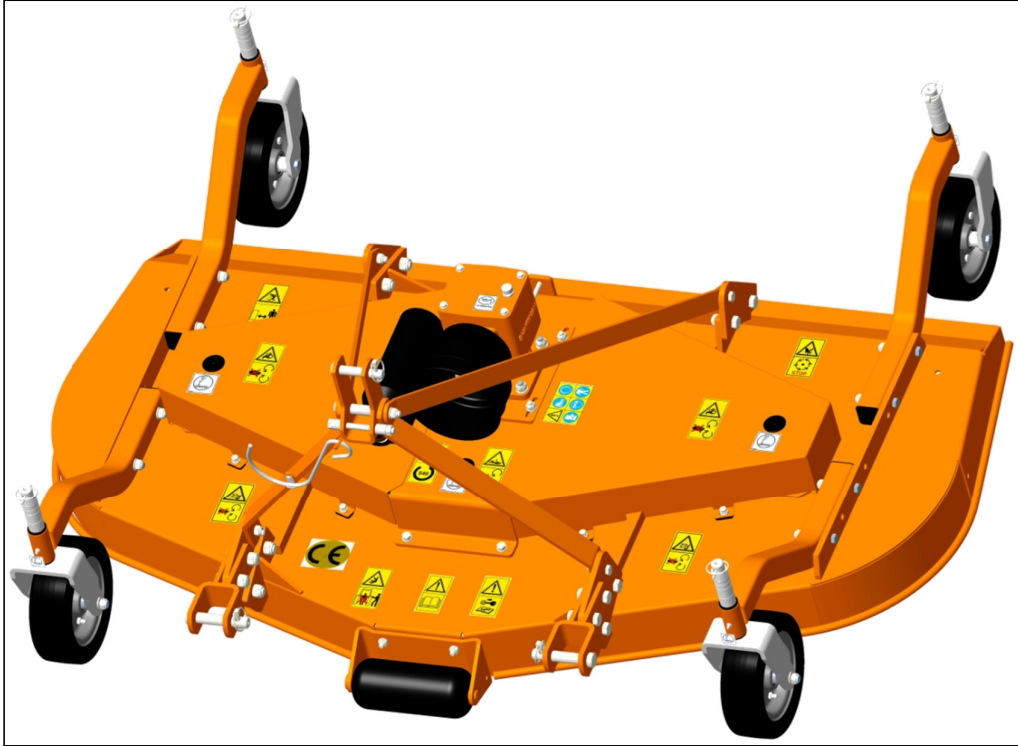

OPERATOR'S AND PARTS MANUAL

FARM-MAXX

Uniform Machinery Corporation

P.O. CAGE 38

4608 Lely Road

Wilson - NC 27893

North Carolina NC 27893

USA

Manual P/N: OM2811-21EN-001_19

Congratulation for purchasing your new UNIFARM grooming mower!

This mower has been designed and manufactured following all safety and quality requirements needed for a safe and satisfactory use over time.

A careful reading of this manual will permit you to familiarize with your new equipment, and will provide you all the tools needed to use it safely.

A proper maintenance and knowledge of the safety rules of use will allow to obtain the best performance and a long service life of the machine.



The Safety Alert Symbol used throughout this manual and on safety decals of the machine indicates the presence of potential hazard to the operator. When you see this symbol, be alert and carefully read the message that follows it.

The Safety Alert Symbol is used in conjunction with following Signal Words, according to the degree of possible injuries that may result operating the implement:



DANGER

Indicates an imminently hazardous situation that, if not avoided, will result in death or serious injury.



WARNING

Indicates a potentially hazardous situation that, if not avoided, could result in death or serious injury, and includes hazards that are exposed when guards are removed. It may also be used to alert against unsafe practices.



CAUTION

Indicates a potentially hazardous situation that, if not avoided, may result in minor or moderate injury. It may also be used to alert against unsafe practices.

IMPORTANT

Indicates instructions or procedures that, if not observed, can cause damage to equipment or environment.

NOTE

Indicates helpful information.

READ, UNDERSTAND, and FOLLOW the safety messages following the Safety Alert Symbol and Signal Words. Failure to comply with safety messages could result in serious bodily injury or death.

TO THE PURCHASER

This manual contains valuable information about UNIFARM GROOMING MOWER. It has been carefully prepared to give you helpful suggestions for operating, adjusting, servicing repair parts.

Keep this manual in a convenient place for quick and easy reference. Study it carefully. You have purchased a dependable and sturdy grooming mower, but only by proper care and operation can you expect to get the service and long life designed and built into it.

RIGHT-HAND AND LEFT-HAND sides are determined by watching from the tractor side.

Sometime in the future your grooming mower may need new parts to replace those are worn or broken. If so, go to nearest UNIFARM dealer and provide him the model and part number.

Customer information

Name _____

Purchased from _____

Purchased date _____

Model No. _____

Serial No. _____

Index

1. ABOUT THIS MANUAL.....	1
2. INTRODUCTION.....	1
2.1. IDENTIFICATION.....	1
2.2. INTENDED USE.....	2
2.3. MAIN PARTS DESCRIPTION	3
2.4. SPECIFICATIONS	4
3. SAFETY.....	5
3.1. GENERAL SAFETY INSTRUCTION.....	5
3.2. EQUIPMENT SAFETY INSTRUCTIONS	6
3.3. OPERATING SAFETY INSTRUCTION.....	7
3.4. TRANSPORTING SAFETY INSTRUCTIONS.....	8
3.5. MAINTENANCE SAFETY INSTRUCTION.....	8
3.6. STORAGE SAFETY INSTRUCTIONS	9
3.7. SAFETY LABELS	10
4. SET UP.....	13
4.1. CONNECTING TO THE TRACTOR.....	13
4.2. DRIVELINE INSTALLATION	15
4.3. TRACTOR-MOWER STABILITY	16
5. OPERATING.....	17
5.1. START UP AND REUSING.....	17
5.2. OPERATING INSTRUCTIONS	19
5.3. ADJUSTMENTS	20
5.4. STOPPING AND DISCONNECTION	25
5.5. TRANSPORT.....	25
6. MAINTENANCE.....	26
6.1. BELTS TENSIONING.....	27
6.2. BELTS REPLACEMENT.....	28
6.3. BLADES REPLACEMENT.....	29
6.4. GEARBOX LUBRICATION	31
6.5. SPINDLE SHAFTS LUBRICATION	31
6.6. WHEELS AND WHEEL SUPPORTS LUBRICATION	32
6.7. DRIVESHAFT MAINTENANCE	33
7. STORAGE.....	33
8. SCRAPPING	33
9. TROUBLESHOOTING.....	34
10. TORQUE VALUES TABLE	35
11. WARRANTY	36
12. SPARE PARTS.....	38

1.ABOUT THIS MANUAL

The operator must read the manual for a correct understanding of the hazards that may present when operating the mower, as well as for obtain optimum performance from the machine.

The manual is part of the machine, it must be kept in good condition and remain with the machine even in case of resale, until its demolition. In case of loss or damage, request a new copy to the Manufacturer or your Dealer.

The information, descriptions and illustrations in this manual describe the state of the product at the time of its publication, and may not reflect the product in the future.

The Manufacturer reserve the right to make design improvements or changes in specifications without incurring in any obligation to install them on units previously sold.

Text, illustrations and drawings of this manual cannot be disclosed or transmitted, in whole or in part, to third parties without the written permission of the Manufacturer. All rights are reserved.

2. INTRODUCTION

2.1. IDENTIFICATION

Each mower is provided with a plate for unique identification (see picture below), showing the CE marking together with following information:

- Manufacturer name and address
- Type of machine ("TYPE")
- Model of machine ("MODEL")
- Serial number ("SERIAL No.")
- Construction year ("YEAR")
- Machine weight ("MASS")
- Speed required at Implement Input Connection ("INPUT").

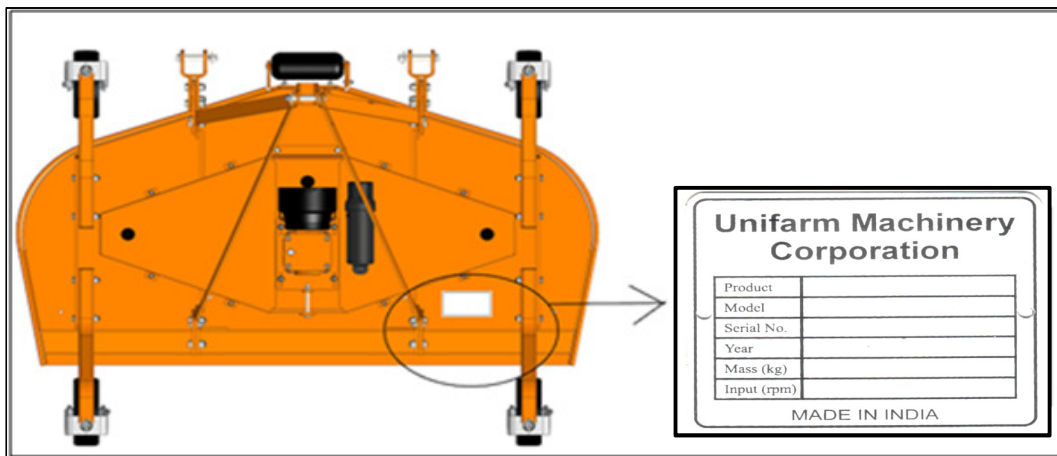

It's recommended to note down all data shown on the plate.

Any request for assistance or information regarding the machine must be directed to the Manufacturer or Dealer always referring to the model and serial number as shown on the plate affixed to the machine.

2.2. INTENDED USE

The SGM-series grooming mowers are specifically designed for lawn and grass professional mowing and maintenance of areas like private lawns, parks, airports, hospital grounds, schools, highways, golf courses etc.

The SGM mowers are NOT designed for rough conditions or heavy weed mowing.

The SGM mowers can be either tractor front or rear mounted on universal three point hitch, and are driven by the tractor power through a PTO driveshaft connected to a speed multiplier gearbox. The power is transmitted by means of two belts from a pulley coupled to the gearbox shaft to three pulleys coupled to individual spindle shafts. Each shaft is equipped with a suction type blade turning at a high tip speed for best results in mowing.

The mowers are provided with 4 swivel wheels that allow to follow the contour of the ground, giving a precise and level cut even in undulating conditions.

The tractors used to operate the SGM-series mowers must have the following requirements:

Hitch Category:	3-point, Category 1 (ISO 730 standard)
PTO:	540 RPM , 6 – SPLINE , 13/8 “26
Horsepower:	As per technical specification.



DANGER

Any use of the machine other than the intended use is non-intended use, and is to be considered as unauthorized and dangerous. The manufacturer assumes no liability for damage resulting from non-intended use.

2.3. MAIN PARTS DESCRIPTION

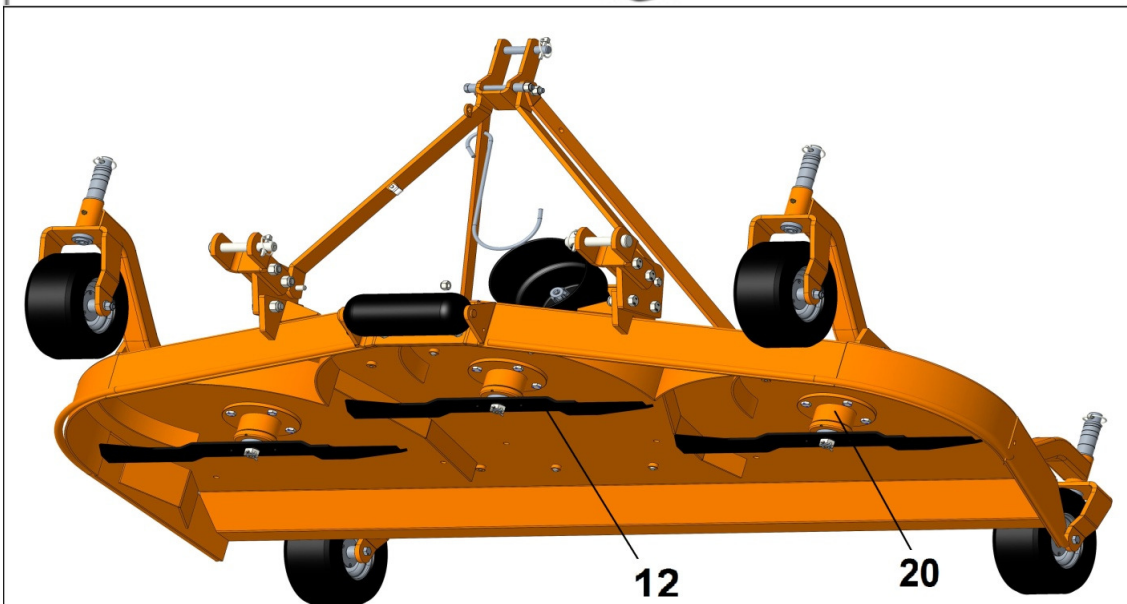
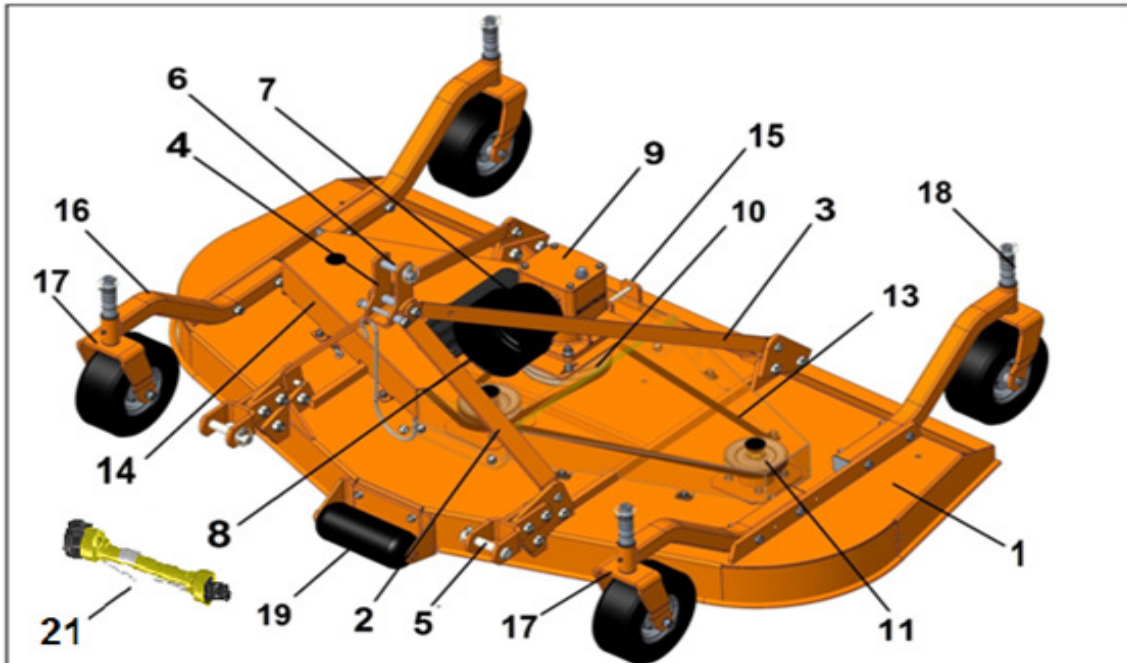

- | | |
|-------------------------------|------------------------------|
| 1. Mower deck | 11. Driven pulley |
| 2. Top hitch support | 12. Blade |
| 3. Top hitch arm | 13. Transmission belt |
| 4. Top hitch link | 14. Belt cover |
| 5. Lower hitch pin | 15. Belt tensioner screw |
| 6. Upper hitch pin | 16. Wheel arm |
| 7. PTO shield | 17. Swivel wheel |
| 8. Implement Input Connection | 18. Height adjusting spacers |
| 9. Gearbox multiplier | 19. Front roller |
| 10. Driving pulley | 20. Blade spindle |
| | 21. Cardan driveshaft |

NOTE

To make the illustrations more clear, some images of this manual may refer to machines lacking of some components (e.g. belt cover).

2.4. SPECIFICATIONS

MODEL		FMR 48 (1.2M)	FMR 60 (1.5M)	FMR 72 (1.8M)	FMR 84 (2.1M)
Overall dimensions	cm	136x134x75	163x147x75	192x152x75	225x173x75
Cutting width	cm	122	150	180	213
	inches	48"	60"	72"	84"
Tractor power	HP	20-50			
3-point Hitch type	-	Category 1 (ISO 730 standard)			
PTO Input speed	rpm	540			
Cutting height	mm	19 - 110			
	inches	3/4" - 4 1/3"			
PTO driveshaft	-	ASAE Cat. 3			
Deck thickness	mm	4,5			
Wheels	-	-	Air		
	-	Air 11x4-5	Air 11x4-5	Air 11x4-5	Air 11x4-5
	-	Solid 10x3.25	Solid 10x3.25	Solid 10x3.25	Solid 10x3.25
Belts (number and type)	-	2 SPB type			
Number of blades	-	3			
Blade size	mm	6x60x424	6x60x516	6x60x618	6x60x725
Blade overlap	mm	25			
Blade shaft speed	rpm	3130	2648	2236	2027
Blade tip speed	fpm	13,681	14,074	14,192	15,275
Spindle type	-	with greaseable ball bearings			
Spindle bearings	-	Bearing 6206			
Front roller	-	Standard			
Unit Weight (*)	Kg/BS	203/448	226/498	251/553	300/661

(*) driveshaft excluded

Note:- Spindle bearing 6205 is also available as per requites.

3. SAFETY

Proper use of the equipment, a strict observance of the safety messages listed below and application of all reasonable practices to avoid any risks, prevents accidents or injury, allows the machine working better and longer, and minimize the failures.

The manufacturer assumes no liability for any damage resulting from not applying the behavioral rules indicated into the manual.

3.1. GENERAL SAFETY INSTRUCTION



DANGER

The machine must be used only by authorized and well trained operators. The operator must have read and understood the instructions of this manual, it must make adequate preparation for the proper use of the machine and must hold a driving license. In case of doubt about the use of the machine and/or the interpretation of this manual, the operator must contact the Manufacturer or the Dealer.



WARNING

The manual must always remain with the machine. In case of loss or damage, request a new copy to the Manufacturer or your Dealer.



WARNING

Follow strictly the rules prescribed by the safety pictograms applied to the machine.



WARNING

Be sure that all safety pictograms are legible. If pictograms are worn, they must be replaced with others obtained from the Manufacturer, and placed in the position indicated by this manual.



DANGER

Before using the machine, make sure that all safety devices are installed and in good working conditions. In case of damages of shields, replace them immediately.



DANGER

Is absolutely forbidden to remove or alter safety devices.



DANGER

Before starting, and during operation of the mower, make sure there are no people or animals in the operation area: the machine can project material from the back, with risks of serious injury or death.



DANGER

Pay maximum attention to avoid any accidental contact with rotating parts of the machine.



DANGER

During operation, adjustment, maintenance, repairing or transportation of the machine, the operator must always use appropriate Personal Protective Equipment (PPE).



DANGER

Do not operate the implement while wearing loose fitting clothing that can give rise to entanglement in parts of the machine.



DANGER

Do not operate the implement when tired, not in good condition or under the influence of alcohol or drugs.

**CAUTION**

If the use of the machine is required at night or in conditions of reduced visibility, use the lighting system of the tractor and possibly an auxiliary lighting system.

3.2. EQUIPMENT SAFETY INSTRUCTIONS

**WARNING**

Use the mower for its intended purpose only. Improper use can damage the implement and cause serious injury to persons, animals, or death.

**DANGER**

The machine should be used by a single operator driving the tractor.

**WARNING**

Any unauthorized modification of the machine may cause problems in safety and relieves the Manufacturer from any liability for damages or injuries that may result to operators, third parties and objects.

**WARNING**

Before using the machine, familiarize yourself with its controls and its working capacity.

**WARNING**

Do not leave the mower unattended with tractor engine running.

**WARNING**

Keep the machine clean from debris and foreign objects which may damage functioning or cause injury.

**WARNING**

Do not use the machine if the category of the connecting pins of the mower does not match that of the tractor hitch system.

**WARNING**

Do not use the machine with missing bolts, screws, pins or safety pins.

**WARNING**

Never use the machine to transport or lift people, animals or objects.

**WARNING**

Make certain, by adding front ballast, that at least 20% of the total weight (tractor, implement and ballast) is on the front axle of the tractor, to ensure stability.

**WARNING**

Before engaging the tractor PTO, make sure the tractor PTO speed is set as required for the mower (540 rpm). Do not over speed PTO or machine breakage may result.

**DANGER**

Do not operate the mower if the driveshaft is damaged. The driveshaft could be subject to breakage during operation, causing serious injury or death. Remove the driveshaft and replace it with an undamaged.

**DANGER**

With mower disconnected from tractor, rest the driveline on the provided support of the mower.

3.3. OPERATING SAFETY INSTRUCTION

**WARNING**

Before using the machine, be sure to have cleared the operating area from obstacles (stones, branches, debris, etc...). Mark all the obstacles that cannot be eliminated (e.g. by means flags).

**DANGER**

Never engage the tractor PTO in the presence of people close to the driveshaft. The body, hair or clothing of a person can get caught in rotating parts, causing serious injury or death.

**DANGER**

Before engaging the PTO and during all operations, make sure that no person or animal is in immediate area of action of the machine. Never use the mower if people are in his working area.

**DANGER**

It's absolutely forbidden to stand near the mower with moving parts.

**WARNING**

The operator must operate mower lifting/lowering only from the driving seat of the tractor. Do not perform lifting maneuvers on side or behind the tractor.

**DANGER**

The presence of steep slopes may cause instability to the system tractor and mower, with risk of tipping and consequent serious injury or death hazard. Consult the manual for the tractor to determine the maximum slope that the tractor is able to deal with.

**DANGER**

Never engage the PTO until the mower is in the down position and resting on the ground. Never raise the mower until all blades have come to a complete stop. The machine might throw objects at high speed, causing serious injury or death.

**WARNING**

Never leave the driver's seat when the tractor is turned on. Before leaving the tractor, lower the mower to the ground, disengage the PTO, insert the parking brake, stop engine and remove the key from the control panel.

**DANGER**

The PTO shields of tractor and implement side, the driveshaft shielding and the driveshaft retaining chains must be properly installed and in good condition, to avoid risk of entanglement with serious injury or death.

**DANGER**

Before engaging the PTO of the tractor, always make sure that the driveshaft is correctly installed, with clamping elements properly connected both to tractor side and to implement side.

**WARNING**

Only operate PTO at 540 rpm. Know how to stop tractor and mower quickly in an emergency.

**WARNING**

Stop operating immediately if blades strike a foreign object. Repair all damage and make certain spindles and blades are in good condition before restarting operation.

 **WARNING**

Always disengage the tractor PTO when the driveshaft exceed an angle of 10 degrees up or down while operating. An excessive angle with driveshaft rotating can break the driveshaft and cause flying projectiles.

 **CAUTION**

Prolonged use of the mower can cause overheating of the gearbox. Do not touch the gearbox during use and immediately after, it could be extremely hot and cause severe burn.

 **WARNING**

All adjustment operations on the mower must be performed by qualified and trained operators, with the tractor engine off, the PTO disengaged, the mower lowered to the ground or on security stands, the ignition key off and the parking brake set.

3.4. TRANSPORTING SAFETY INSTRUCTIONS

 **WARNING**

Before transporting, determine the stopping characteristics of the tractor and implement.

 **WARNING**

Transport only at speeds where you can maintain control of the equipment.

 **WARNING**

When driving on roads, the implement must be in transport position adequately raised from the road surface, with tractor lifting hydraulics locked so that the mower cannot be lowered accidentally.

 **DANGER**

The implement may be wider than the tractor. Pay attention during transporting to persons, animals or obstacles exposed.

 **WARNING**

When turning, use extreme care and reduce tractor speed.

 **WARNING**

Do not operate the tractor with weak or faulty brakes or worn tires.

 **CAUTION**

Always use tractor lighting system and auxiliary lighting system for an adequate warning to operators of other vehicles, especially when transporting at night or in conditions of reduced visibility.

 **DANGER**

In case of mower lifting, make sure that the lifting device chosen is suitable to perform the operation safely, and use only the lifting points prescribed on mower.

3.5. MAINTENANCE SAFETY INSTRUCTION

 **WARNING**

All maintenance and repairing operations must be performed by qualified and trained operators, with the tractor engine off, the PTO disengaged, the mower lowered to the ground or on security stands, the parking brake and the set ignition key off. Secure blocking prevents equipment from dropping due to hydraulic leak down, hydraulic system failures, or mechanical component failures.

 **WARNING**

Perform repairs and replacements necessary to the mower using only original spare parts provided by the manufacturer or your Dealer.

 **DANGER**

Perform maintenance operations always using appropriate Personal Protective Equipment (protective eye glasses, hard hat, hearing protection, safety shoes, overall and work gloves, filter mask).

 **CAUTION**

Before any maintenance operation, make sure that the parts which may become hot during use (gear box) have cooled.

 **WARNING**

Do not perform repairs that you do not know. Always follow the manual instructions and in case of doubt contact the Manufacturer or your Dealer.

 **DANGER**

Do not swallow fuels or lubricants. In case of accidental contact with eyes, rinse well with water and consult a doctor.

3.6. STORAGE SAFETY INSTRUCTIONS

 **WARNING**

Never leave the tractor unattended with the mower in lifted position. Accidental operation of lifting lever or a hydraulic failure may cause sudden drop of unit with injury or death by crushing.

 **DANGER**

Following operation, or before unhooking the mower, stop the tractor, set the brakes, disengage the PTO, lower the attached mower to the ground, shut off the engine, remove the ignition key and wait for all moving parts to stop.

 **WARNING**

Make sure all parked machines are on a hard, level surface and engage all safety devices.

 **CAUTION**

Store the unit in an area away from human activity.

3.7. SAFETY LABELS

The safety labels applied on the machine give fundamental information for using the machine safely.





Make sure safety labels are in good conditions. If pictograms are worn, they must be replaced with others obtained from the Manufacturer and placed in the position indicated by this manual.

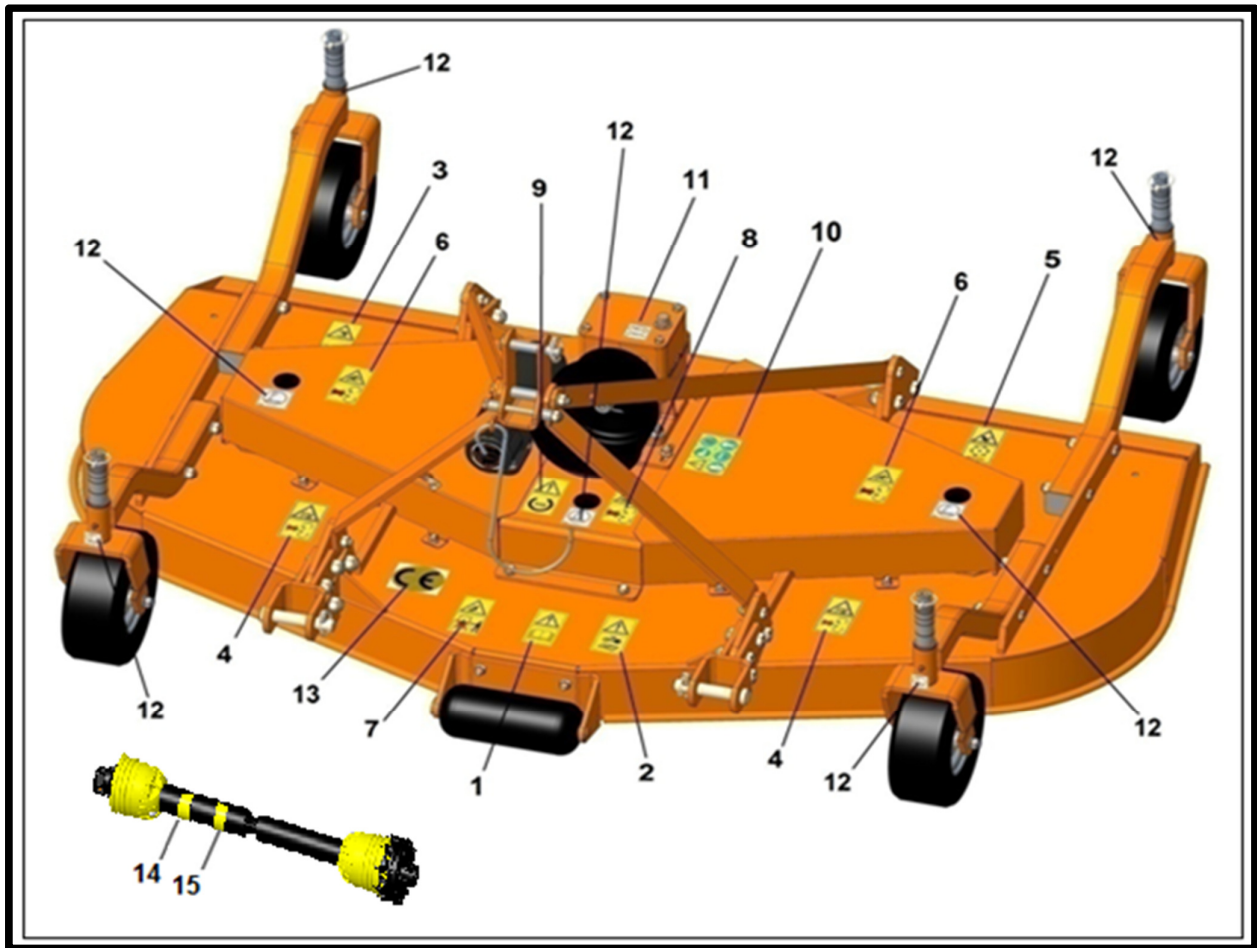





Make sure the safety labels are legible. If necessary, wipe them by a cloth, with soap and water.



SAFETY LABELS POSITION AND DESCRIPTION



SR. NO.	SPARE CODE	DECALS	DESCRIPTION
1	D1090		Carefully read the operator's manuals of mower, tractor and cardan shaft before using the machine.

2	D1038		<p>Disengage the PTO, turn off the tractor engine, remove the key and ensure that all rotating parts have stopped before approaching the implement. Read the operator's manual before performing any maintenance operation.</p>
3	D1095		<p>Thrown or flying object hazard. Keep a safe distance from the machine.</p>
4	D1132		<p>Rotating blades: Severing of lower limbs hazard. Keep a safe distance from the machine.</p>
5	D1078		<p>Cutting of fingers or hand hazard. Wait until all machine components have completely stopped before touching them.</p>
6	D1079		<p>Rotating gear: fingers or hand entanglement hazard. Do not open or remove safety shields while engine is running.</p>

7	D1097		Crushing hazard. stay clear of draft link lifting range while in operation.
8	D1098		Implement input driveline: body entanglement hazard. Do not open or remove safety shields while engine is running.
9	D1099		Before engaging the tractor PTO, check that rpm rate and sense of rotation are those prescribed for the implement.
10	D1082		Always engaging clothing and equipment appropriate for the job: Hearing protection, safety shoes, safety gloves, safety glasses and overall.
11	D1007		Oil filling point
12	D1008		Greasing point

13	D1123		ROTATING DRIVELINE (COVER)
14	D1124		ROTATING DRIVELINE (TUBE)

4. SET UP

The mower is delivered equipped with a driveshaft and related operating manual.

When the machine is delivered, check that there is no damage to the mower or driveshaft. In case of damage or missing parts immediately notify the Manufacturer or your Dealer.

Because of his size, the mower could be delivered with some parts disassembled. In this case, the assembly of such parts is an owner's task, and must be carefully performed with reference to the layout tables of the Spare parts section.



ATTENTION

For proper tightening torques of bolts and screws, refer to the section Torque values table of the manual.

4.1. CONNECTING TO THE TRACTOR

The SGM mowers are designed to be mounted on tractors up to 50 hp equipped with 3-point Hitch Category 1 (ISO 730 standard).



WARNING

Check the tractor PTO to ensure it is set at 540 rpm and turns clockwise.



WARNING

Before connect the implement to the tractor, make sure that tractor and mower are on a flat, stable and dry surface.

To connect the mower to the tractor the operator must do the following:

- drive the tractor in reverse up to the mower, in order to slip the tractor hitch arms over the hitch pins of the mower (see picture below);

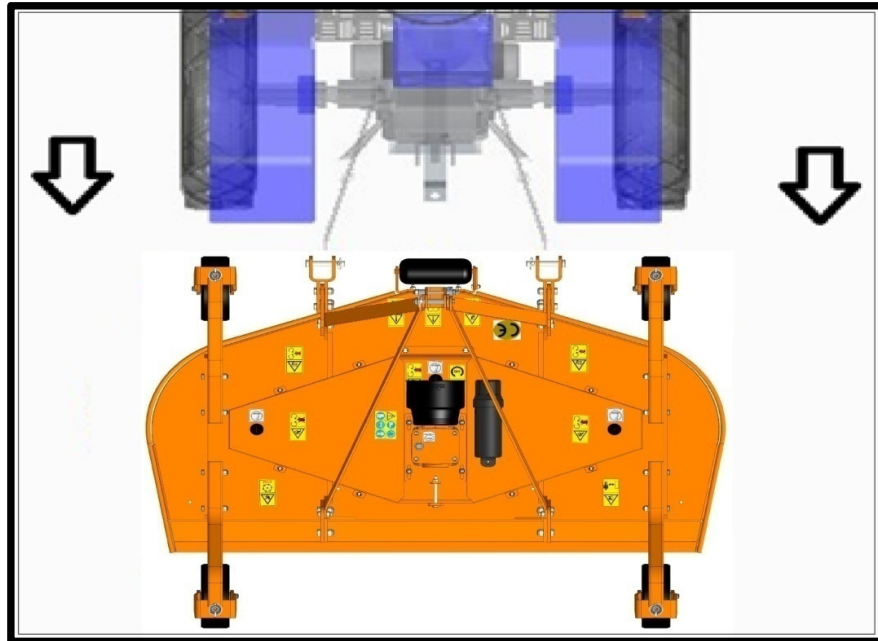

- set the tractor's parking brake, stop engine, remove the ignition key and get off the tractor;
- connect the lifting arms of the tractor to the lower hitches of the mower, through the use of the pins and relative safety split pins;
- adjust the tractor sway blocks or chains to remove all side movement;
- connect the tractor top link to the mower top link plate through the relative pin and safety split pin. The 3-point hitch system of the mower is designed to have a limited front to back flotation when mowing on uneven terrain. Adjust the tractor's top link until the top link plate of the mower is in vertical position respect to the deck (see picture below), in order to allow the mower to follow the ground contour during mowing operation.

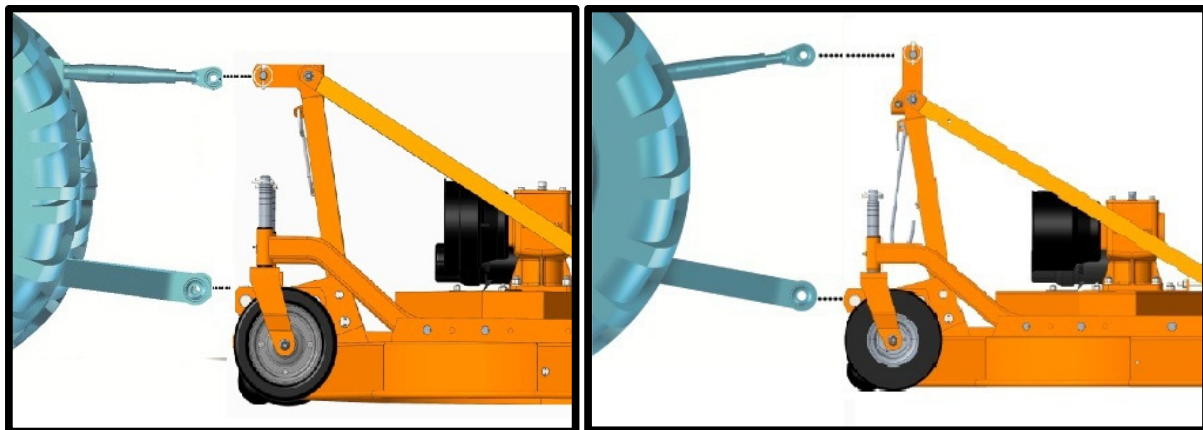

- check the interference between mower's front wheel arms and tractor wheels. If there is interference, adjust the position of the mower front wheel arms according to instruction described in section Wheel arms adjustment;
- proceed with the driveline connection (see Section Driveline installation).

4.2. DRIVELINE INSTALLATION

Before installing the driveshaft, the operator must read the manuals of the tractor and driveshaft, checking in particular that rpm and direction of rotation of the PTO tractor match those of the mower.

If the direction of rotation of the PTO tractor does not match that of the mower, contact the Manufacturer or your Dealer.

To connect the driveshaft to the tractor and implement, the operator must:

- park tractor and mower on a flat surface, with parking brake set, engine off, and ignition key removed;
- check that driveshaft, mower and tractor safety shields are in good condition, otherwise provide for their replacement;
- remove the PTO shield of the mower through the fixing screws;
- insert the driveline yoke on the mower PTO by first lining up the splines, then ensure its tightening onto the shaft through its fastener/snap pin;
- replace the PTO shield of the mower through the fixing screws;
- insert the driveline yoke on the tractor PTO, then ensure its tightening onto shaft through its fastener/snap pin;
- hook to the tractor and mower the two retaining chains of the driveline shielding, to prevent shielding rotation during functioning of the machine. The chains should not be too tight.



WARNING

The driveline must not exceed an angle of 15 degrees up or down while operating. Exceeding this angle with driveline rotating can break the driveline and cause safety hazard to operator and bystanders. Always work with the driveline as straight as possible. This will prolong life of driveline and that of its components, avoiding premature breakdowns.

Driveline Length Check

Before operating the mower, ensure that the size of driveshaft is adequate. The driveshaft supplied with the machine has a standard length, therefore it may need an adaptation of the length, depending of the tractor which the mower is combined.

The length of the driveshaft must be such to:

- avoid bottom out of the transmission tubes, when the driveshaft is in compressed position (when the mower is raised up off the ground);
- ensure an overlapping of the transmission tubes enough to transmit the torque required, when the driveshaft is in max extension (when the mower is in its lowest position in the ground).

When the driveshaft is at its minimum length (max compressed position), there must be at least a 2 cm of distance between the ends of each transmission tube and the yokes side.

When the driveshaft is at its maximum operational extension, there must be an overlap between the tubes profiles of 15 cm at least.

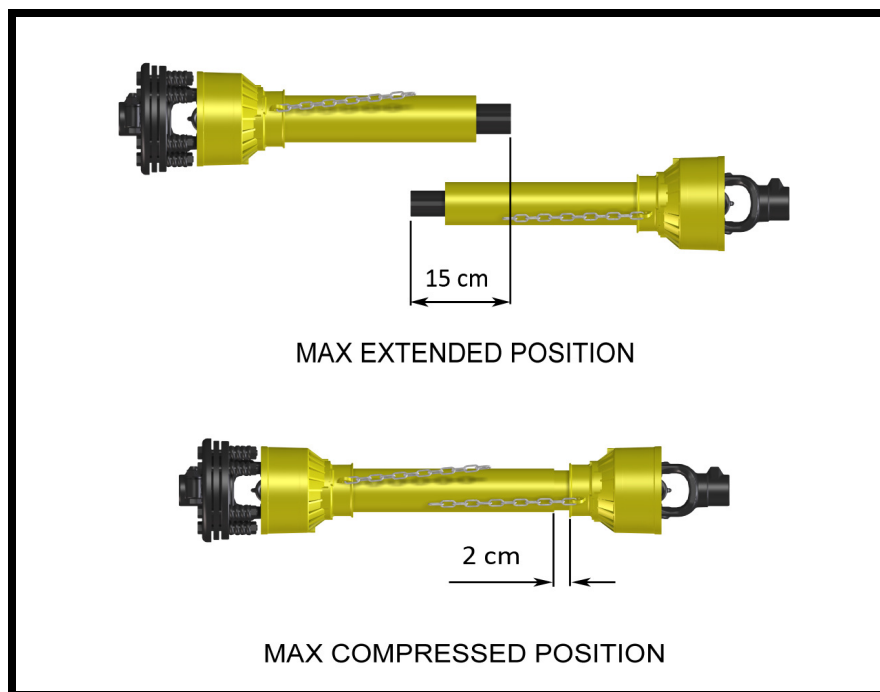

A driveshaft too long may cause structural damages to the tractor and machine. If the driveshaft is too long, it may be adapted by removing it and shortening the tubes according to the instructions provided by the Manufacturer in its use and maintenance manual.

A driveshaft too short can cause disengage of the tubes during operation, with severe hazard for the operator and structural damage to the tractor and machine. If the driveshaft is too short, it must be replaced with a longer one. In this case contact the Manufacturer or your Dealer.

IMPORTANT

- before operating the mower the first time, or before reusing the mower after a long term storage, make sure that the driveshaft is lubricated in accordance with how indicated in his own instruction booklet;
- always engage the tractor PTO at low rpm to minimize the effect of the peak torque on the driveline and the machine.

4.3. TRACTOR-MOWER STABILITY

Before connecting the machine to the tractor is required to check the stability of the tractor-machine system, in order to determine the ballast to apply to the front of the tractor, to ensure adequate distribution of the weight on the axles when the implement is in lifted position (e.g. for transportation).

In order to assure the stability it is necessary that the following relations are verified (see table below for definitions):

$$1) M \times (S1+S2) \leq 0.2 \times T \times i + Z \times (d+i)$$

$$2) M \leq 0.3T$$

Consequently, the minimum ballast required is:

$$Z_{min} = (M \times (S1+S2) - 0.2 \times T \times i) / (d+i).$$

To determine the appropriate characteristics of the ballast, refer to the manual of the tractor.

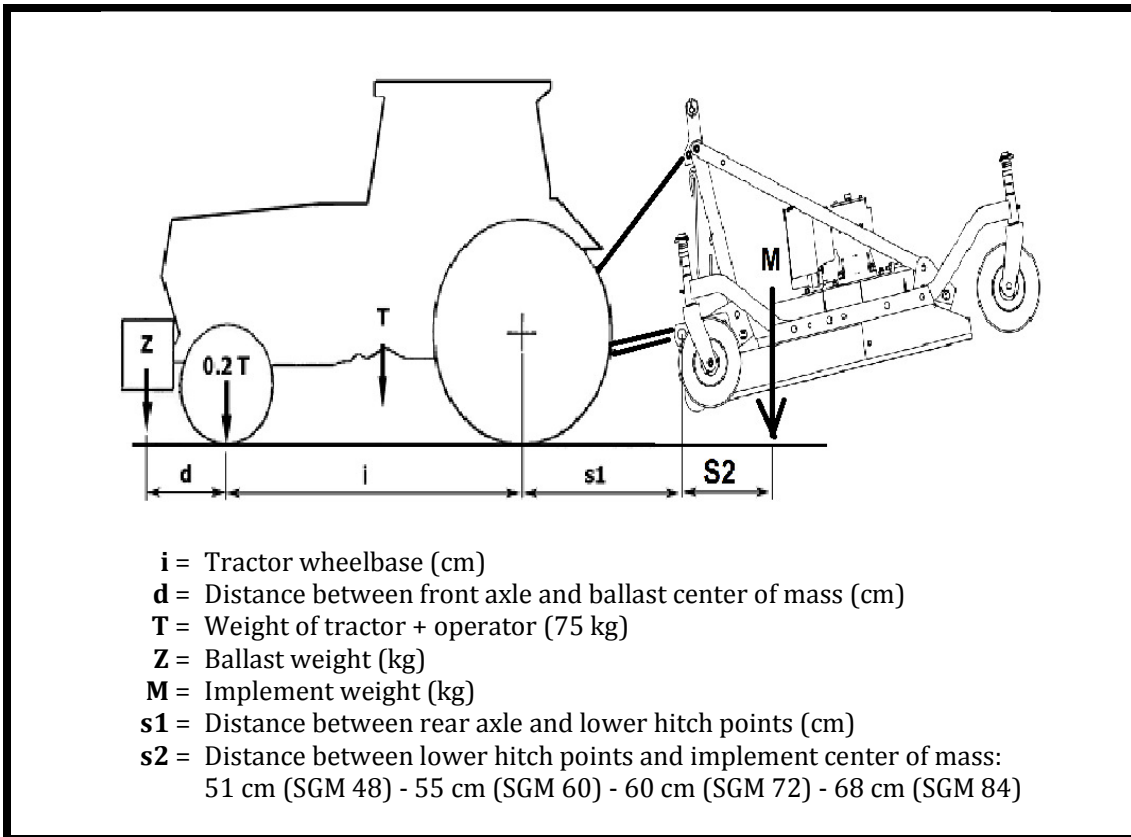

CAUTION

The weight of the implement modifies the stability of the system tractor-mower, resulting in loss of steering control and braking.

5. OPERATING

Before operate the mower, make sure you have read and understood the operating manuals of the mower, tractor and PTO shaft, and followed what is described in the section "Set Up".



DANGER

During operation, adjustment, maintenance, repairing or transportation of the machine, the operator must always use appropriate Personal Protective Equipment (PPE).

Before starting work, ensure that tractor, implement and driveline's safety guards are in good conditions and fully functional.

5.1. START UP AND REUSING

Before the start up and before reusing the mower after a long term storage (e.g. after seasonal end), perform the following **pre-operational inspections and service of the implement**, to assure that the machine is in perfect condition and ready to be used:

- check that the mower has not damaged functional parts and has all mechanical parts in good condition. Repair and / or replace the damaged parts;
- check that the mower has no missing parts (pins, safety pins, plugs oil ...). Restore the missing parts;
- check that all guards and safety devices have no damages and are properly positioned. Repair and / or replace the damaged shielding, restore the correct position;

- verify that the PTO driveshaft is properly installed (see section: Connection of the driveshaft);
- check the presence of lubricant in all greasing points of the blade spindles, wheel arms and driveshaft (see section Maintenance);
- check for possible oil leaks from the gearbox. Identify the reason of loss, then repair and / or replace the damaged components;
- check the correct oil level in the gearbox (see section Maintenance);
- check the belts for proper tension (see section Maintenance);
- check that spacers wheels are all at the same height (see section Cutting height adjustment);
- check that blades are not excessively worn and the relating hardware is correctly tightened (see section Maintenance);
- check that all the mower hardware is properly tightened. Refer to the tightening table in the manual for proper torque values;
- check that all safety decals are correctly positioned, in good condition and legible. Replace any damaged decals;
- check that there is no constraints that may prevent the movement of equipment, such as wrappings or foreign objects around the blades, belts or driveline. Remove any constraint.
- check the tractor, to ensure correct direction of PTO and rpm speed.



WARNING

Before the start up and whenever the coupling tractor is changed, check the interference between mower's front wheel arms and tractor wheels. Do not operate tractor and mower until this interference check has been performed. If there is interference, adjust position of the mower front wheel arms according to instruction described in section Wheel arms adjustment.

Before the start up and before each use, make the following **checks on the operating area** identified for tillage:

- check that area is clear of foreign objects (rocks, branches or debris). Remove any obstacle and visibly highlight obstacles that cannot be eliminated (e.g. by means flags);
- make sure in the working area exposed there are no people or animals.



WARNING

Before conducting the above inspections and service, make sure the tractor engine is off, all rotation parts are completely stopped and the tractor is in park with the parking brake engaged. Make sure the mower is resting on the ground or securely blocked up.

Once all the checks above have been done, start tractor and mower as follows:

- start engine tractor and engage the tractor PTO at low rpm, making sure that the mower is in the down position and resting on the ground, then increase speed engine until to 540 rpm;
- start driving the tractor at low speed. Subsequently increase the ground speed until the desired speed is obtained, depending on ground conditions (see section Operating instruction);
- drive for a while operating the mower, then stop the tractor to check the quality of the work performed and if the mower is adjusted properly. Once you have made necessary adjustments (see section Adjustments), you may continue mowing following the instruction of section Operating instruction to operate properly the mower and get the desired finish cutting. If you need to get off the tractor, leave the mower in the down position and resting on the ground, reduce engine speed and disengage PTO, set the parking brake, stop engine and remove the ignition key.

5.2. OPERATING INSTRUCTIONS

The SGM-series grooming mowers have been designed to cut grass with heights up to 8". It is recommended to avoid cutting grass taller than 10".

Always operate tractor PTO at 540 rpm to maintain proper blades speed and obtain a clean cut.

The proper tractor ground speed should be selected considering: height, type and density of grass, grass condition (wet or dry), and ground condition (hilly, level, or rough). Generally a ground speed from 2 to 5 mph (2-8 km/h) applies to most conditions. A test run is suggested to define the optimal working speed for proper own conditions.

Tall, dense grass should be cut at low speed, while thin medium-height grass can be cut at a faster ground speed. Generally, the grass dispersion is increased by higher ground speeds.

Extremely tall grass should be cut in two passes. Set mower to a high cutting height on the first pass, then position the mower at the desired height on the second pass. If possible, mow at a 90 degree angle in travel to the first pass.

Under certain conditions, tractor tires may roll some grass down and prevent it from being cut at the same height as the surrounding area. When this occurs, reduce the tractor ground speed but maintain a 540 rpm engine speed: the lower ground speed will permit the grass to partially rebound, thanks to the suction effect of the blades. If grass will not rebound enough to be cut evenly, resulting in an uneven and not satisfactory appearance, cut the area twice.

In general, lower cutting height gives a more even cut with less tendency to leave tire tracks. However, it is better to cut grass more often, rather than too short. Short grass deteriorates rapidly in hot weather and invites weed growth during growing season.

Very low cutting heights should be avoided. Damaging shock loads occur when the blades strike the ground repeatedly. This can cause damage to the mower.

IMPORTANT

For cleaner cuts and efficient mowing, the blades must be kept sharp. Sharp blades produce cleaner cuts and require less power.

During operations:

- always keep the tractor engine at 540 rpm rate ensuring to blades the right rotating speed required for the use;
- always keep a tractor speed adequate to ground conditions 2 to 5 mph (2-8 km/h). Reduce speed in the case of hard or stony soils;
- when increasing or decreasing mowing ground speed, use gear selection (not engine speed). This will maintain the constant maximum blade speed necessary for a clean cut.
- choose a driving pattern that provides the maximum pass length and minimizes turning; Plan your pattern to travel straight forward whenever possible
- when working in the hills, if you can do "climbing" in the sense of the slope, in any case do not work along the hillsides, making the steps from top to bottom to reduce the terrace Where possible always try to «work up» the slope. If this is not possible avoid hoeing along the contours of the hill and hoe up and down the slope to avoid a terracing effect;
- enter new areas carefully. Cut grass higher at first, allowing mower to clear hidden objects;
- periodically check for foreign objects wrapped around the blades and/or rotor blades and remove them, after disengaging PTO, turning off tractor engine, and removing ignition key;
- if the blades strike a foreign object, stop operating immediately, idle the engine speed and disengage the PTO. Wait for stopping of all rotating parts, then raise the implement and proceed to removing possible objects or debris, after stopped the tractor, set the parking brake, stopped engine and removed the ignition key. Make sure rotor and blades are in good condition before restarting operation. Repair any damages immediately;

If at any time the mower should jam, causing belt slippage for over two seconds, follow these steps:

- bring the equipment into a previously cut area, allowing mower to clear accumulated material;
- continue running for 2-3 minutes, allowing pulleys to cool. Stopping the mower in contact with a very hot pulley will bake and ruin belt.

Typical problems that may occur operating the mower are described into Troubleshooting section, together with their solutions.



DANGER

During operation, the machine can throw material at very high speed from the back, which could result in personal or property damage. Pick up all rocks and other debris before mowing. Prevent people and animals to approach the operational area.

When working on uneven terrain, observe following precautions:

- use extreme care and reduce ground speed on slopes and rough terrain;
- use rear wheel weights, front tractor weights, and/or tire ballast to improve stability in extremely uneven terrain;
- develop a safe working pattern suitable for the ground profile;
- pass diagonally through sharp dips and avoid sharp drops to prevent hanging up the tractor and implement;
- operate the implement up and down steep slopes, DO NOT operate across steep slopes, to prevent the tractor from tipping;
- do not stop, start, or change directions suddenly on slopes;
- watch for hidden hazards on the terrain during operation.

IMPORTANT

An anti-scalping roller is highly recommended for uneven terrains. The roller allows the front part of the mower to ride over the mounds, helping to keep the mower from scratching the ground and the blades from scalping the terrain.

5.3. ADJUSTMENTS



WARNING

All adjustment operations must be performed with the tractor engine off, the PTO disengaged, the mower lowered to the ground or on security stands, the parking brake set and the ignition key off. Secure blocking prevents equipment from dropping due to hydraulic leak down, hydraulic system failures, or mechanical component failures.

CUTTING HEIGHT ADJUSTMENT

The cutting height is the distance from the blades to the ground. It determines the height of the mowed grass.

The cutting height can be adjusted by moving the position of the spacers (A) on the four wheel yokes (see picture below):

- placing spacers between the wheel arm and the wheel yoke raises the cutting height by the size of the spacer;

- Removing spacers between the wheel arm and the wheel yoke lowers the cutting height by the size of the spacer.

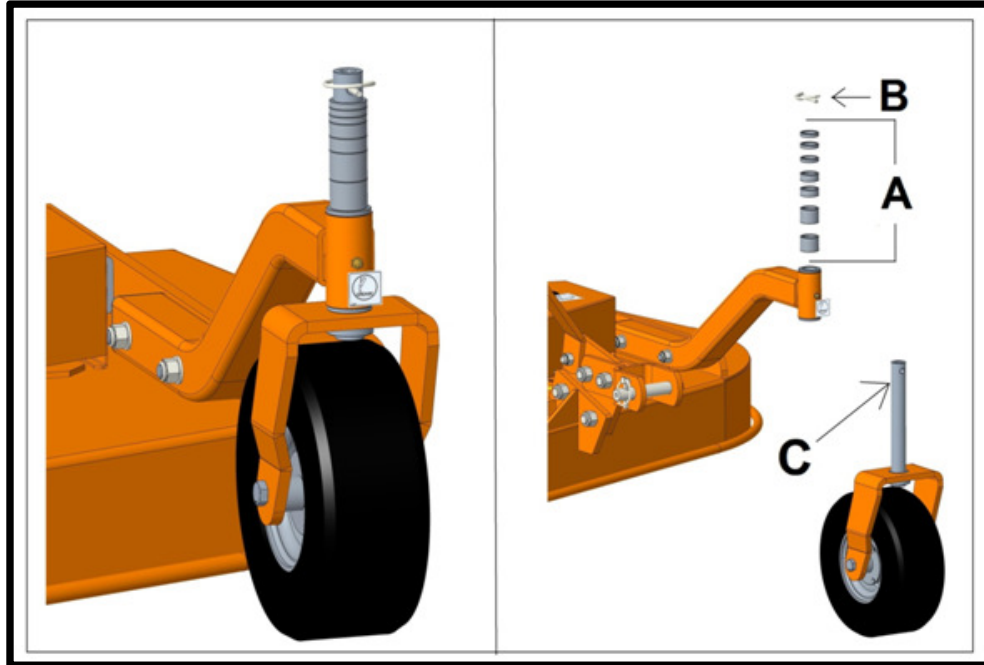

The SGM mowers have cutting height adjustable from 1" to 5". To adjust the working depth, perform following steps:

- using the tractor, raise mower off the ground and support under it with secure blocking to keep the mower from dropping down during adjustment operations;
- holding wheel and yoke assembly up, remove the lynch pin (B) from top of gauge wheel spindle (C);
- position the spacers (A) as desired. The spacers are assorted with heights of 1/4"-1/2" and 1", to allow adjustment at multiple levels of cutting heights (from 1" to 5");
- replace the lynch pin on top of gauge wheel spindle;
- repeat the same for the other three wheels. Verify that the same amount of spacers are under all 4 caster arms: only an equal adjustment ensure a completely uniform cut;
- remove safety block, than put mower down on the ground.

IMPORTANT:

Very low cutting heights should be avoided. Damaging shock loads occur when the blades strike the ground. This can cause damage to the mower and drive.

WHEEL ARM ADJUSTMENT

The front wheel arms of the SGM60-72-84 mowers (*) can be set in two different configurations:

- inner position (see picture below - left side), that allows the outside edge of the mower to be used for trimming under shrubs or fences;
- outer position (see picture below - right side), that provides the most clearance to avoid interference with tractor tires.

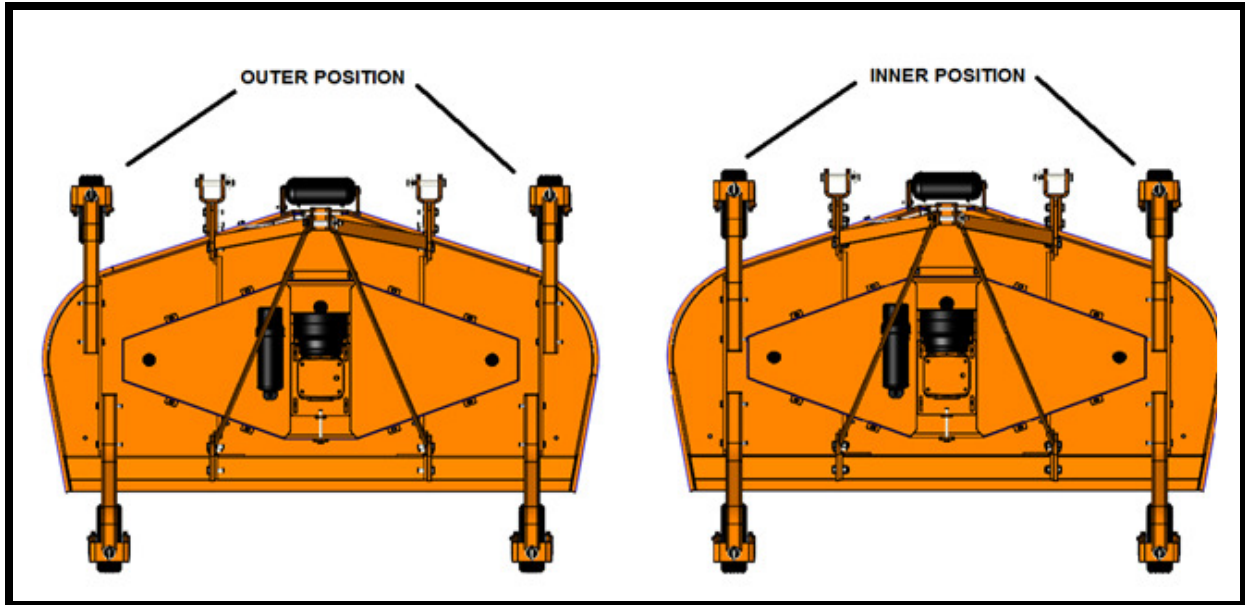

To change configuration, do the following (see picture below):

- remove the screws (A), washer (B) and nuts (C) connecting the front wheel arm to the rail (D) welded to the frame. To simplify the adjustment procedure, the belt cover (E) can be removed from mower frame;
- move the arm (F) from one side of the rail to the other.
- position the arm according to proper own requirement, then secure them to the wheel rail through the original hardware. Replace the belt cover if disassembled.
- repeat the procedure for the other front wheel arm.

The rear wheel arms usually don't need to be moved, and should remain mounted in their original position.

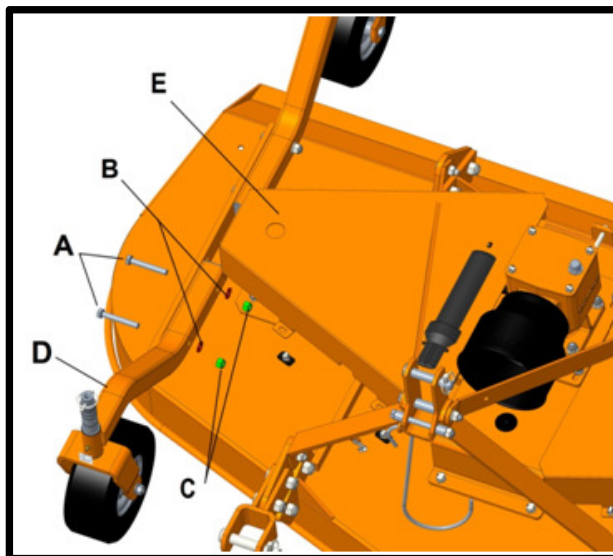

(*) NOTE:

SGM48 front wheel arms are fixed and cannot be changed.

LOWER HITCHES ADJUSTMENT

The lower hitched of the SGM mowers can be set in two different configurations:

- fixed position (see picture below - left side);
- floating position (see picture below - right side), that allows the mower to float and follow contour over hilly and uneven terrain.

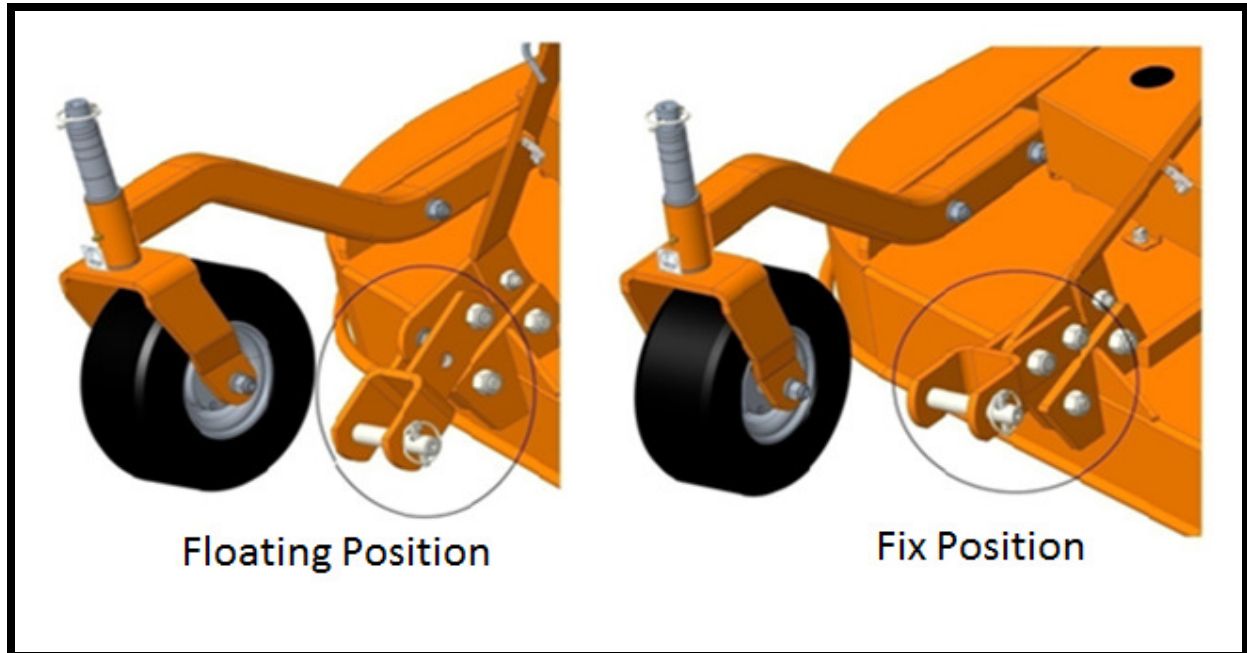

To change from fixed to floating position, remove screw (A), nut (B) and bushing (C) clamping the two bent plates (D) to the front plate (E) welded to the frame.

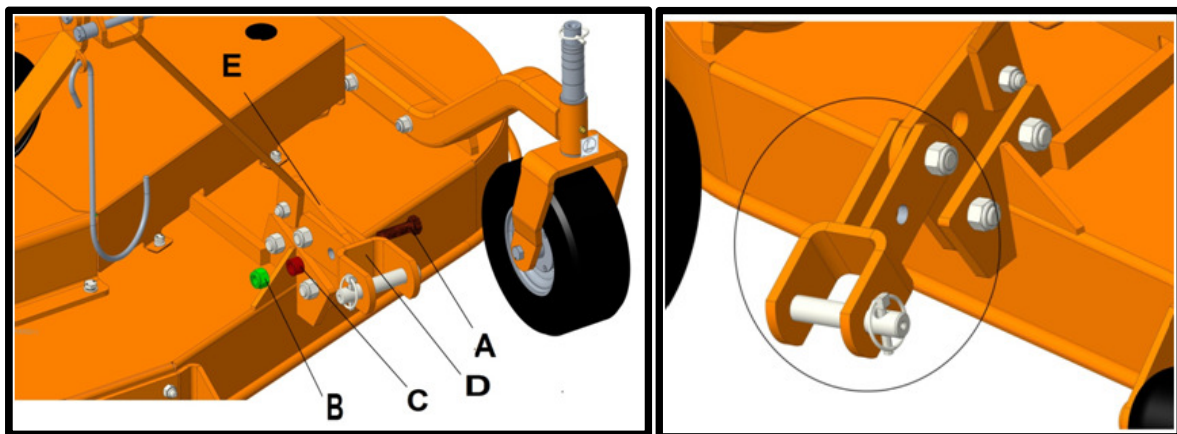

To maximize the floating effect, providing at the same time the most clearance for interference with tractor tires, the lower hitches can be moved ahead (see picture):

UPPER HITCHES ADJUSTMENT

The upper hitched of the SGM mowers can be set in two different configurations:

- fixed position (see picture below);
- floating position (see picture below), that allows the mower to float and follow contour over hilly and uneven terrain.

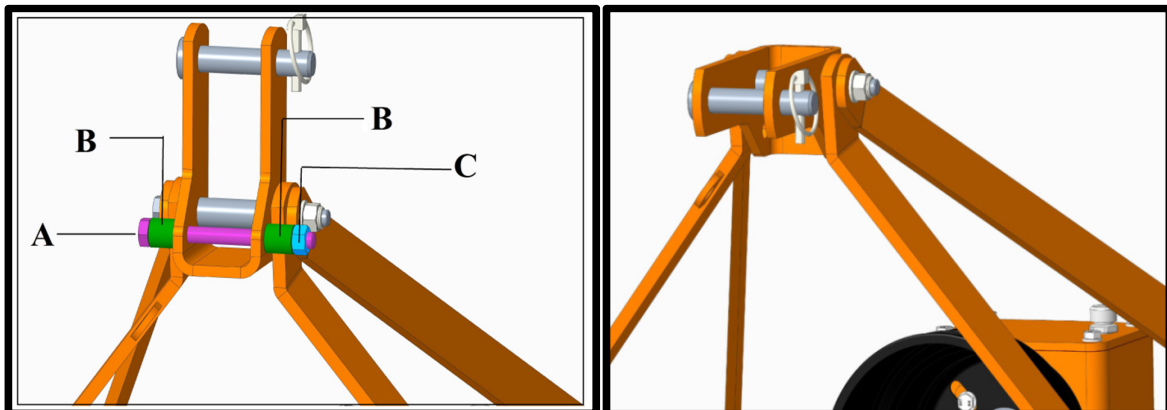
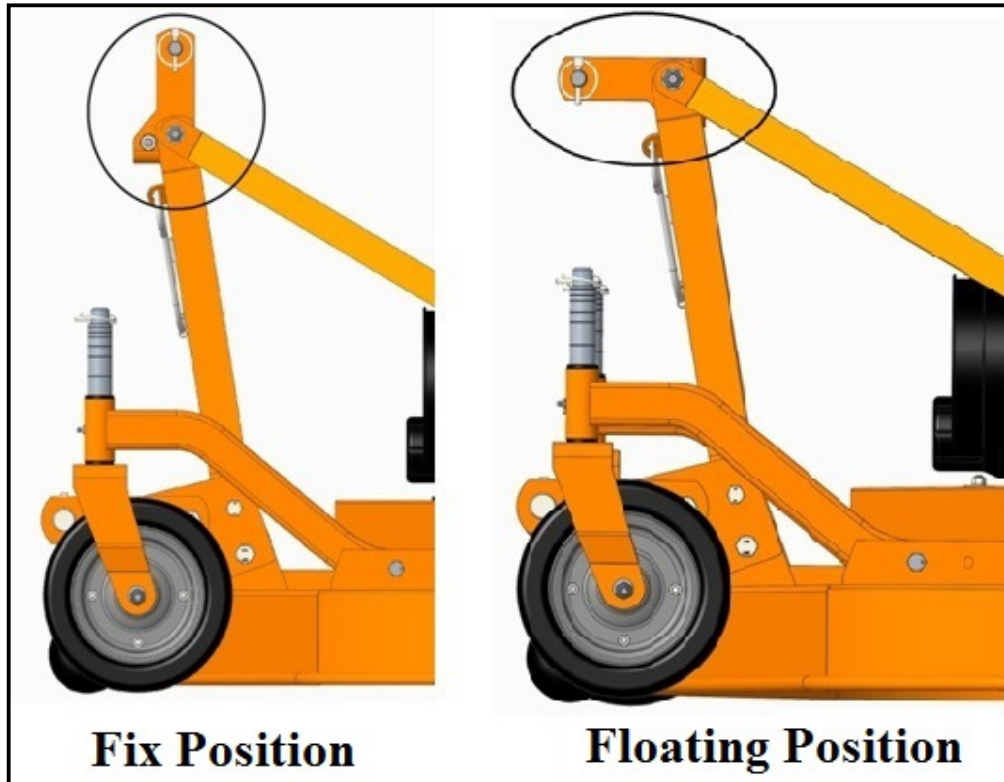

To change from fixed to floating position, of 3 - point hitching bracket , remove hex bolt (A), two bush (B) & nut (c) from bracket.

5.4. STOPPING AND DISCONNECTION

To **stop** the mower at the end of a working session:

- bring the tractor on a dry and level surface;
- stop the tractor and place the transmission in park or neutral;
- reduce the engine speed, then disengage the PTO;
- wait for stopping of all rotating parts;
- set the parking brake;
- shut down the engine and remove the key before exiting the tractor;
- do the cleaning and maintenance required to make the machine ready for later use (see section Maintenance).



WARNING

Never leave the tractor unattended with the implement in the lifted position.

To **disconnect** the mower from the tractor (e.g. to make a change of implement):

- bring the tractor on a dry and level surface;
- stop the tractor and place the transmission in park or neutral;
- reduce the engine speed, then disengage PTO;
- wait for stopping of all rotating parts;
- set the parking brake;
- shut down the engine and remove the key before exiting the tractor;
- disconnect the driveline from the tractor PTO and rest it on and store in appropriate place;
- disconnect the top link and the rear lifting arms of the tractor from the mower hitches;
- check the mower stability. If needed, place safety blocks;
- get on the tractor, start the engine and move away from the mower slowly;
- make sure that the mower remains stored in a protected area, to prevent that unauthorized personnel can approach it.

Before a long term storage (e.g. at seasonal end), do cleaning and maintenance operations as specified in sections Maintenance and Storage.

S

5.5. TRANSPORT

To set the mower for transportation, perform the following steps:

- idle tractor engine, disengage tractor PTO, and wait for stopping of all rotating parts;
- adjust the tractor top link so that when lifted, the rear of the machine is higher than the front. To do this, shorten the tractor top link until the top hitch plate is locked forward and no longer able to pivot. This will keep the mower locked and minimize the shaking and bouncing during transport, avoiding damages to the hitch a frame.
- lift the mower until the transport position, making sure the driveline transmission tubes does not hit either the tractor or the gearbox mower. A minimum gap of 2 cm should be leaved between the tubes and tractor and mower (see also section Driveline installation). The mower should not be lifted over 14"-16" from the ground.

- lock the tractor lifting hydraulics, turn off the engine, set the parking brake, remove ignition key and get off the tractor.



CAUTION

Make sure PTO is disengaged and blades have stopped turning before raising mower to transport position.



WARNING

Never leave the tractor unattended with the implement in the lifted position.

During transportation:

- Always use caution and select a safe ground speed that is appropriate for the terrain. Reduce speed when under adverse surface conditions, turning, or on inclines. Take care that the implement does not strike obstacles such as trees, fences or buildings.
- Do not operate PTO. Always transport the implement with disengaged PTO.
- A minimum 20% of tractor and equipment weight must be applied to the front wheels when attachments are in transport position. Without this weight, front tractor wheels could raise up resulting in loss of steering. The weight may be attained with front wheel weights, ballast in tires or front tractor weights.
- Do not transport on steep slopes.
- Do not transport equipment while under the influence of alcohol or drugs.
- Never allow riders on power unit or attachment.
- When driving on public roads, install a SMV (Slow Moving Vehicle) sign. Always comply strictly with all federal, state and local laws and traffic regulations.



WARNING

When driving on public roads, reduce your speed, be aware of traffic around you and proceed in such a way that faster moving vehicles may pass you safely.

6. MAINTENANCE

Proper and regular maintenance ensures a long life of your implement, avoids failures and saves time and repair costs.

Periodic inspections and maintenance operations described in this section must be performed by operator in the times and terms prescribed. Failure to comply with maintenance prescriptions can compromise the functioning and duration of the machine, and consequently invalidate the warranty.

The frequency of maintenance indicated refers to normal conditions of use: it must be intensified in severe or unusual operating conditions (frequent stops and starts, prolonged cutting season etc ...).

Repairs, maintenance and modifications other than those mentioned in this paragraph should NOT be performed without consulting the Manufacturer or your Dealer. Manufacturer, as the case, may give the authorization to proceed with the repair together with all necessary instructions.

Wrong or inappropriate repairs or maintenance may generate abnormal operating conditions, equipment damage and generate risks for the operator.



WARNING

For safety reasons, all maintenance operations must be performed with tractor PTO disengaged, mower stopped and completely lowered to the ground or onto support blocks, parking brake set, tractor engine shut off, and ignition key removed.



WARNING

Perform maintenance operations always using appropriate Personal Protective Equipment (protective eye glasses, hard hat, safety shoes, overall and work gloves, filter mask).

IMPORTANT

Respect the environment. Store or dispose of unused chemicals as specified by the chemical Manufacturer.

6.1. BELTS TENSIONING

Applying the right tension on the belts drive system is crucial to have a correct functioning of the mower. Excessive tension on the belts may lead to premature failure of belts and drive components, and may also lead to a safety hazard to the operator or bystanders. Lacking tension on the belts may lead to their premature failure due to excessive slipping.

To check belts tension (see picture below):

- remove belt cover (A) and apply a force of 11-13 lbs (5-6 kg) pushing against the belt halfway between the pulleys (at point B). The belt deflection should be approx 3/8" (1 cm). If bigger, proceed with belts tension adjustment. Perform the check on both belts.

If deflection of one of the two belts is significantly different from the other, or belts are stretched or damaged, belts should be replaced (see Belts replacement).

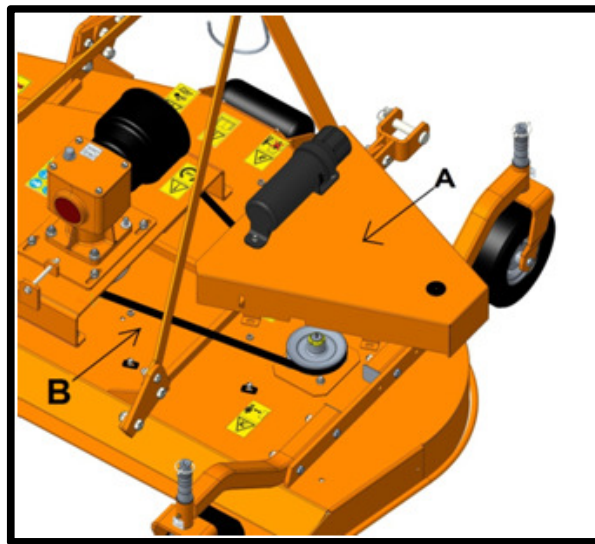

To adjust belts tension (see picture below):

- remove belt cover (A). Clean debris and foreign material from the mower deck and belt area;
- loosen the four nuts (B) holding the gearbox support plate (C) to the gearbox support (D);
- loosen the blocking nut (E) on the adjustment bolt (F);
- turn the adjustment bolt clockwise. This will bring the gearbox support plate to move backwards, tensioning the two belts at the same time at the same time. Stop turning the bolt when the proper belts tension is reached. Turn the adjustment bolt counterclockwise to loose the belts tension;
- retighten the blocking nut on the adjustment bolt;
- retighten the four nuts holding the gearbox support to the gearbox support;
- reinstall the belt cover.

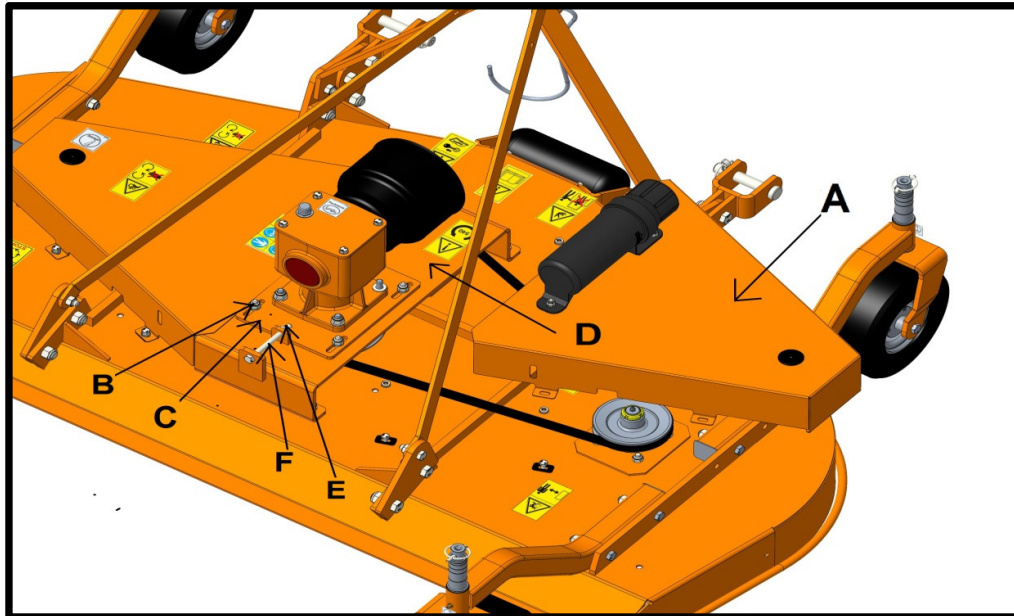

6.2. BELTS REPLACEMENT

Belts replacements is required if belts are stretched or damaged to the point that the proper tension cannot be obtained.

To replace belts do the following (see picture above):

- remove belt covers (A). Clean foreign material from the mower deck and belt area;
- loosen the four nuts (B) holding the gearbox support plate (C) to the gearbox support (D);
- loosen the blocking nut (E) on the adjustment bolt (F);
- turn the adjustment bolt counterclockwise, pushing the gearbox support plate forward until belt tension is fully released;
- remove old belts, and dispose them properly;
- replace new belts. Be sure that belts are correctly positioned in all pulley grooves. When correctly in pulley grooves, belts are arranged parallel to the mower deck;
- turn the adjustment bolt clockwise. This will bring the gearbox support plate to move backwards, tensioning the two belts at the same time. Stop turning the bolt when the proper belts tension is reached;
- tighten the blocking nut on the adjustment bolt;
- retighten the four nuts holding the gearbox support to the central plate. Replace the belt covers.



WARNING

The two belts must be always replaced at the same time.
Before installing new belts:

- check that pulley shafts and bearings are in good condition, and make sure that spindles turn freely and without wobble. Replace worned parts;
- check pulley grooves for cleanliness. If grooves require cleaning, use a cloth moisturized with a non-flammable, non-toxic degreasing agent or commercial detergent and water.

IMPORTANT

Do not apply excessive force during belts installation. Do not use tools to pry belt into pulley groove. Do not roll belt over pulleys to install. This can cause hidden damage and premature belt failure.

6.3. BLADES REPLACEMENT

A proper blades maintenance is crucial to allow the mower to work properly, and to assure a precision cut with lower HP requirements and reduction of tractor fuel consumption.

Frequently check the blades through visual inspection to see if they are bent, deformed or split. Blades must be kept sharp, at their original length and shape. A blade must be replaced if, due to wear or damage, its original shape is deformed.

Operate the mower with blades in bad condition compromise the quality of cutting.

To perform blades replacement do the following (see pictures below):

- Remove block the blade shaft by fitting a wrench in special spacer (B) and unscrew blade GUA self-locking nut (C);
- remove the bevel spring (D) and the blade to be replaced (E). Clean bevel washer, gua self-locking nut (C) and mounting surface of all debris. Dispose the blade properly;
- install the new blade, making sure that blade cutting edge is towards the direction of rotation (the blade turns in a counter clockwise direction when viewed from the bottom of the mower);
- reinstall the conical spring and the gua self-locking nut. Tighten the gua self-locking nut, blocking the blade shaft by fitting a wrench in special spacer, and align the hole on blade shaft end to one of gua self-locking nut slots;
- reinstall safety split pin.

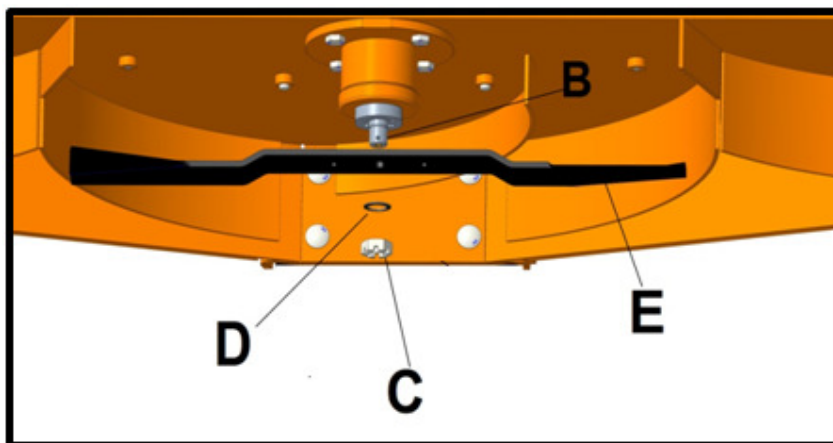
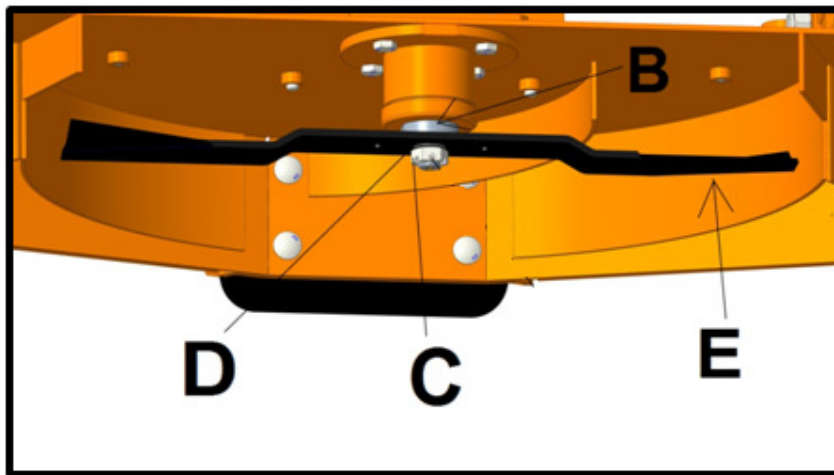

IMPORTANT

After replacement, always make sure that the blade installed has the cutting edge facing direction of rotation.

Replace worn tines only with original parts.



WARNING

DO NOT attempt to straighten or weld damaged blades for reuse, but remove and replace them with new blades.



CAUTION

Worn tines may be very sharp!

BLADES SHARPENING

Worn or nicked blades, if not damaged, can be sharpened in order to restore the high quality of cutting, lower the HP requirements and reduce tractor fuel consumption.

To sharpen blades do the following:

- remove blade according to instructions described into section Blades replacement;
- clean blade, bevel washer, GUA self-locking nut and mounting surface of all debris;
- put the blade in a vise and sharpen it by using a hand grinder. Grind cutting edge at the same bevel as the original. Sharpen only the top of the cutting edge. Do not sharpen the blades to a razor edge. The cutting edge should be approx 1 mm;
- sharpen the ends of the blade equally and maintain corners. Check blade balance by positioning the blade horizontally on a shaft through the center hole. Balance of a blade can be maintained by removing an equal amount of material from each end of the blade when sharpening;
- replace the sharpened blade on the spindle according to instructions described into section Blades replacement.



WARNING

Unbalanced blades cause excessive vibration that can result in damages to blade spindle bearings, mower components and/or personal injury. Always sharpen both ends of the blade equally or until the blade is balanced. Always keep all three mower blades sharpened equally in order to maintain balance.



WARNING

Always wear eye protection and gloves when sharpening a blade.

NOTE

Blade performance will be reduced as blades are resharpened.

6.4. GEARBOX LUBRICATION

Lubricant: SAE EP 140 gear oil (or equivalent).

Check the oil level every 50 hours, making sure that the mark left from the oil on the dipstick of the breather plug (A) is located between the two reference marks (minimum and maximum).

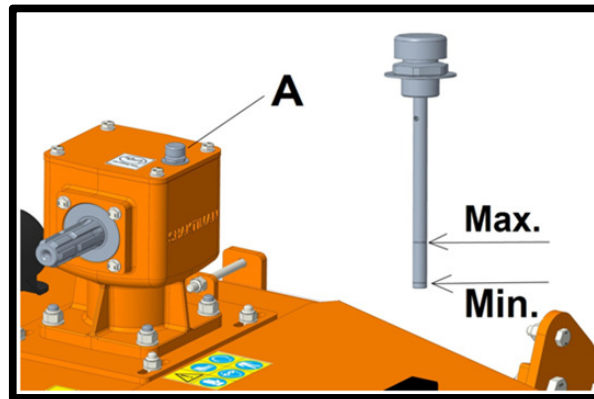

If the mark is below the minimum, fill up oil till restore the correct level.

The oil change must be performed:

- after the first 50 working hours;
- each 500 working hours.



CAUTION

Before touching the gearbox wait until it has cooled sufficiently.



WARNING

Do not overfill gearbox with oil. Oil will expand when hot! Make sure mower is cool before checking oil level. Overfilling the gearbox will cause the excess oil to blow out vent plug and ruin the belt.

IMPORTANT

Frequently check for possible oil leaks from gearbox through visual inspection, and in case of leakage provide immediately proper maintenance.

Avoid oil leaks on the ground when restoring oil level or making oil change.

6.5. SPINDLE SHAFTS LUBRICATION

Lubricant: SAE MULTI – PURPOSE lithium -type grease (or equivalent).

The blades spindles shafts are supported by two bearings that require regular lubrication. Grease fittings points (A) are placed on the top of the three spindle shafts, protected by special rubber caps (see picture below).

Greasing operation can be done by means a greasing gun from the top of the deck, without remove belts cover or plastic caps.

It is suggested to grease the spindles shafts every 25 working hours.

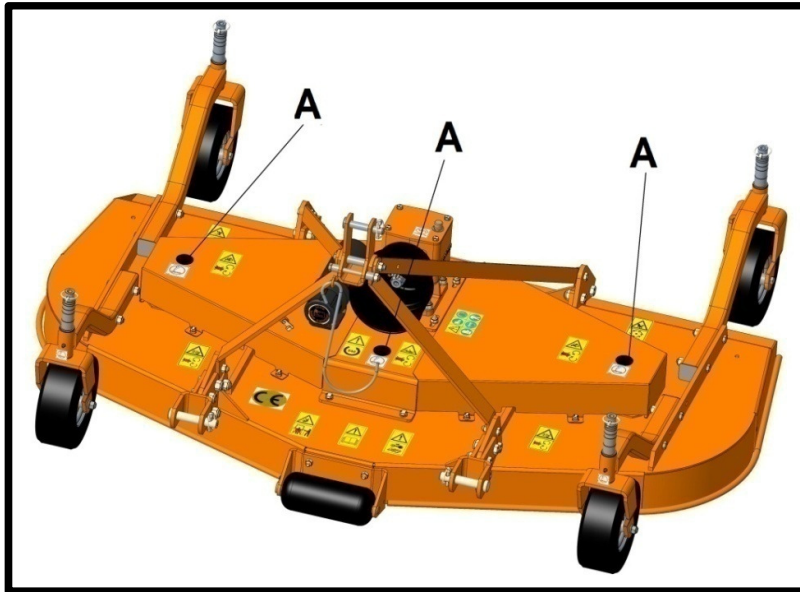

IMPORTANT

Make sure to clean the fitting zerk before using the grease gun.

Do not let excess grease collect on or around parts, particularly when operating in sandy areas.

6.6. WHEELS AND WHEEL SUPPORTS LUBRICATION

Lubricant: SAE MULTI – PURPOSE lithium -type grease (or equivalent).

Lubricate the swivel wheel yokes every 8 working hours through the grease fittings points placed on the wheels support (A - see picture).

Depending on their type, the wheels may present a grease lubrication point for wheel bearings (B). If so, perform lubrication every 8 hours.

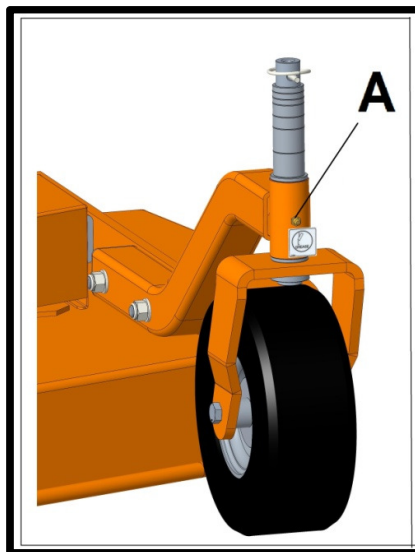

IMPORTANT

Make sure to clean the fitting zerk before using the grease gun.

Do not let excess grease collect on or around parts, particularly when operating in sandy areas.

6.7. DRIVESHAFT MAINTENANCE

Lubricant: SAE multi-purpose lithium-type grease

Grease crosses, sliding parts of protective shielding and driveshaft transmission tubes (see picture below) every 8 working hours.

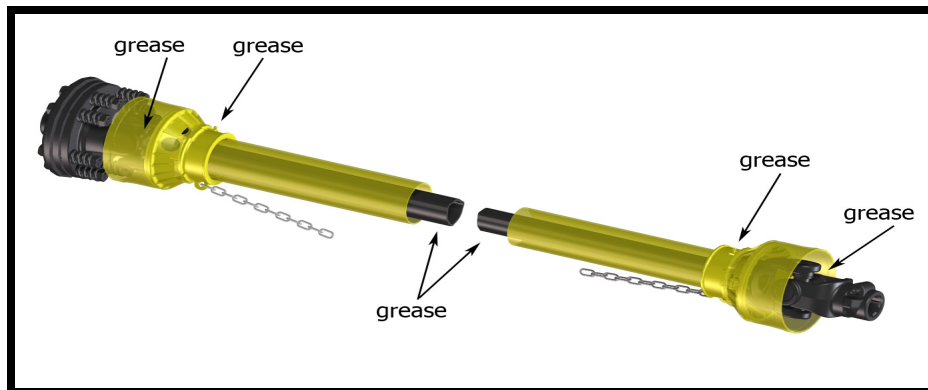

IMPORTANT

For details about maintenance and lubrication of the driveshaft, refer to the user manual of the driveshaft Manufacturer.

NOTE

For replacement of the driveshaft service parts, refer to the user manual of the driveshaft Manufacturer.

7. STORAGE

Before leaving the mower unused for a long time, perform following tasks to preserve the appearance and functionality of the implement, and to make easier the restart at later use:

- park the mower on a flat surface, in a place dry and protected from exposition to the elements, possibly with storage temperature between 0 and 50 °C (see section Stopping and disconnection);
- thoroughly clean the machine, removing from the blades clumps of dirt and all residues due to mowing, in order to avoid damage from grass and stagnant water;
- inspect carefully the machine, checking for worn and/or damaged parts. Perform immediately all repairs and/or replacements needed, in order to make the machine ready for restarting;
- in case of abrasion of painted surfaces, provide restoring the surface protection through touch-up paint to prevent rust;
- make sure the safety decals are in their original positions, intact and legible. When required, replace the decals immediately;
- lubricate properly all grease points, and restore the oil levels as indicated in the Maintenance section. Use protective oil to coat the exposed mechanical components and to protect them against rust.

8. SCRAPPING

In case of scrapping, the machine must be disposed in appropriate and authorized sites, according to local legislation of the Country where the machine is used.

Before scrapping, separate plastic parts from rubber parts, aluminum, steel, etc.

Recover and dispose any exhausted oils to authorized centers for oil collecting.

9. TROUBLESHOOTING

PROBLEM	POSSIBLE CAUSE	POSSIBLE SOLUTION
Excessive vibration	Breakage or excessive wear of blades	Replace the worn or cracked blades
	Spindle shaft bearings worn	Replace bearings
Uneven cutting	Blades assembled incorrectly on spindle shafts	Check spindle assembly and restore correct position of the parts (blade, spacer and washer)
	Height of mower not leveled	Verify that same amount of spacers are under the four caster arms. Level mower adjusting spacers
	Belt tension not enough	Adjust proper belt tension
	Ground speed too fast	Shift to a lower gear
	Blades need sharpening/balancing	Sharpen/balance blades or replace
	Caster wheels uneven	Adjust wheel position
	Loose blade	Check blade hardware
Imperfect cut	Ground speed too low	Increase ground speed
	Tractor rpm too slow	Increase tractor rpm, check engine and PTO speeds
Blades scalping grass	Cutting height too low	Raise cutting height by adjusting wheels
	Hilly ground	Change mowing pattern. Reduce speed turns
Blades turning but not cutting	Direction of blades is wrong	Check the blades have cutting edges facing direction of rotation
Excessive vibration	Blades damaged	Replace blades
	Belts damaged	Replace drive belt
	Pulleys/bearings damaged	Replace pulleys/bearings
	Object wrapped around blade	Remove belt guard shields, clean debris from belt area
	Object wrapped around belt area	Remove object
Belt slipping	Debris clogging mower	Unplug and clean mower deck
	Debris clogging belts area	Remove belt guard shields and clean belts area
	Lack of tension	Tighten belts
	Belt worn or damaged	Replace belt
Belt squealing	Belts slipping	Tighten belts
Gearbox overheating	Low oil level	Add oil.
Oil leaking from gearbox	Gearbox overfilled	Drain to proper level
	Damaged breather plug	Replace breather plug
	Damaged seals	Replace seals

Rear discharge area plugged	Wet grass	Wait until grass dries
	Grass too high	Raise cutting height of mower and cut grass in two pass. Shift transmission to a lower gear.
	Tractor rpm too slow	Mow at full throttle (540 PTO rpm), check PTO speed and tractor engine
Overheating of belts	Incorrect tension of belts	Check tension
	Transmission axis and rotor axis out of alignment	Check alignment
Blades worn/damaged frequently	Cutting height too low, blades touching ground	Raise cutting height
Patches/streaks of uncut grass	Too wet to mow	Allow grass to dry
	Blades unable to cut part of grass pressed down by wheels	Keep engine speed at full PTO but slow ground speed shifting to lower gear. Lower cutting height
	Dull blades	Sharpen/replace blade
	Tip blades worn, preventing overlap	Replace blades
	Loose blade	Check blade hardware
Tractor loaded down by mower	Engine speed too low	Keep engine speed at full PTO. Shifting to lower gear
	Debris clogging mower	Clean mower

10. TORQUE VALUES TABLE

Check frequently hardware to make sure that screws and bolts are tightened according to torque values listed in following table:

BOLT SIZE (METRIC)	8.8 grade		10.9 grade	
	N m	Ft lb	N m	Ft lb
M6	11	8	15	11
M8	26	19	36	27
M10	52	39	72	53
M12	91	67	125	93
M14	145	105	200	150
M16	225	165	315	230
M18	310	230	405	300
M20	440	325	610	450

11. WARRANTY

M/s. Tirth Agro Technology Pvt. Ltd. offer the following warranty to the purchaser of UNIFARM equipment mentioned herein above subject to the conditions set out herein after provided the UNIFARM equipment shall be in the possession of and used by such purchaser from the date of delivery.

M/s. Tirth Agro Technology Pvt. Ltd. Warrants its products for a period of twelve (12) months from date of delivery, for manufacturing or material defects only. Failed part will be replaced at its authorized dealers only and any part component there of that shall be examined by them, shall disclose if to be defective. This warranty shall not apply to equipment or parts that have been subject to negligence, or accident, or not maintained as per company instructions specified in operator manual or that have been altered or repaired or used with non-genuine parts or abused or due to contaminated oil or used in not recommended application.

Warranty Terms & Conditions:

- 1) The purchaser of UNIFARM equipment should strictly follow the instruction given in the instruction manual provided by the company along with the UNIFARM equipment at the time of delivery. Changes if any, resulting in improper usage will not be covered by the warranty. This warranty will automatically terminate on the expiry of warranty period of Six months even the UNIFARM equipment may not be in use for any time during the warranty period for any reason whatsoever including any technical reasons and time taken for such repairs/replacement of parts, and in transit, whether under this warranty or otherwise shall not be excluded from the warranty period.
- 2) All wear and tear items like bearings, chains, sprockets, oil seals, tines, blades, rubber parts and gaskets are not covered under warranty.
- 3) All items with normal wear or failure due to normal wear will not be covered under warranty.
- 4) While the company or authorized dealers will make every effort to carry out repairs/replacement of parts under this warranty as soon as possible. It is expressly made clear that the company shall not be liable to do within any specific period of time.

In the event of repairs/replacement of any parts, this warranty will thereafter continue to remain in force only for the unexpired period of warranty.
- 5) It is entirely left to company discretion to repair/replacement of parts at the site of delivery or at the authorized service points of its dealers. The defective parts which has/have been agreed to be replaced, should be returned to the company without any further claim.
- 6) The warranty shall not cover any consequential or resulting liability, damage or loss arising directly or indirectly out of any defect in the UNIFARM equipment. This warranty shall be strictly limited to repairs and replacement of the defective parts specified in the warranty, and does not cover any reimbursement of labour charges for any repairs so earned out at dealer/client end.
- 7) This warranty shall not be extended in any case of replacement or return of the UNIFARM equipment as a whole. Only failed parts will be covered under warranty.
- 8) The purchasers of UNIFARM equipment will itself fully responsible for model/variant selection.
- 9) This warranty does not cover for statutory duties and taxes like excise, service tax or CST or VAT or State sales tax and octroi and any other local taxes payable on any of the parts which the company may supply or repairs free of cost during the warranty period.

- 10) This warranty also does not cover the cost of packaging, to and fro freight and transportation charges etc., on the defective UNIFARM equipment or other parts of the UNIFARM equipment sent to company's works in Rajkot or to the authorized service station.
- 11) **Warranty becomes void if:**
 - a) The UNIFARM equipment has not been delivered, assembled, started and put into operation by the company or its authorized representative.
 - b) The dully filled delivery certificate is not in our possession within 15 days from the date of delivery.
 - c) The UNIFARM equipment or any parts thereof is subjected to neglect, fire, floods or other acts of God or if in the company's opinion any damage has caused to the UNIFARM equipment during transportation.
 - d) The original serial number is removed, obliterated or altered from the unit.
 - e) Any attempt is made to have the repairs executed by a person or persons, other than the company or its authorized representative.
 - f) Any defect is not informed immediately to the company or its authorized representative, any alteration in warranty card is made.
 - g) Whenever the user or anyone else on his behalf applies equipment to the tractor or to prime mover that has not been expressly approved by the manufacturer or not suitable to the equipment.
- 12)
 - a) Any changes in the location of the UNIFARM equipment or in the/its ownership thereof during the warranty period must be intimated in writing to the company or its authorized dealer within ten days before the change. Failure to do so will absolve the company from the obligation under this warranty.
 - b) Further, in the case of shifting for the continuation of the Warranty, the UNIFARM equipment has to be inspected by the company or its authorized representative before shifting from the original location and before using it at the new location. The inspection free levied by the company or its authorized representative as well as the cost of rectification of any damage in transit, detected in the above inspection, shall be borne by the purchaser/owner, if at the time of restarting, the UNIFARM equipment is found to be in working order, this warranty shall continue to be in force for the remaining period of the warranty.
 - c) Damage to the UNIFARM equipment or any part thereof caused during shifting or transportation is not covered by this warranty.
- 13) None of the company representative or authorized dealer is authorized to alter/amend any terms and conditions of this warranty policy. Only the management of the company is authorized to do so. The decision of the company will be final and binding to the purchaser.
- 14) This warranty policy shall be governed by and construed in accordance with the laws of India and the courts in Rajkot shall have exclusive jurisdiction.
- 15) This warranty is given in lieu of all other guarantees and condition expressed or implied by law or by the any person purporting to act on behalf of the company and excludes every condition, warranty or guarantee not herein expressly set out.

Note: The parts/material that are not covered by this warranty are as follows:

1. Blades
2. Universal joint cross
3. Paint
4. Bearings
5. Rubber parts
6. Gaskets
7. Fasteners
8. Fabrication
9. Chains & sprockets
10. Tines

12. SPARE PARTS

All repairs and replacements on the machine must be performed only by using original spare parts, which must be obtained from the Manufacturer or your Dealer.

This section contains the information needed to identify the parts of SGM series mowers that may be ordered to Manufacturer.

When request spare parts to Manufacturer, always give following indications:

- type of machine;
- machine serial number;
- description and p/number of the spare parts;
- quantities.

NOTE

For identification of p/numbers and description of safety decals refer to the Section Safety labels.

For identification of p/numbers and description of PTO driveline parts, refer to the manual of the driveshaft Manufacturer.

The Manufacturer reserves the right to substitute a required part with an equivalent part, if applicable.

SGM SERIES GROOMING MOWER - SPARE PARTS TABLE_1 - KIT FRAME ASSEMBLY

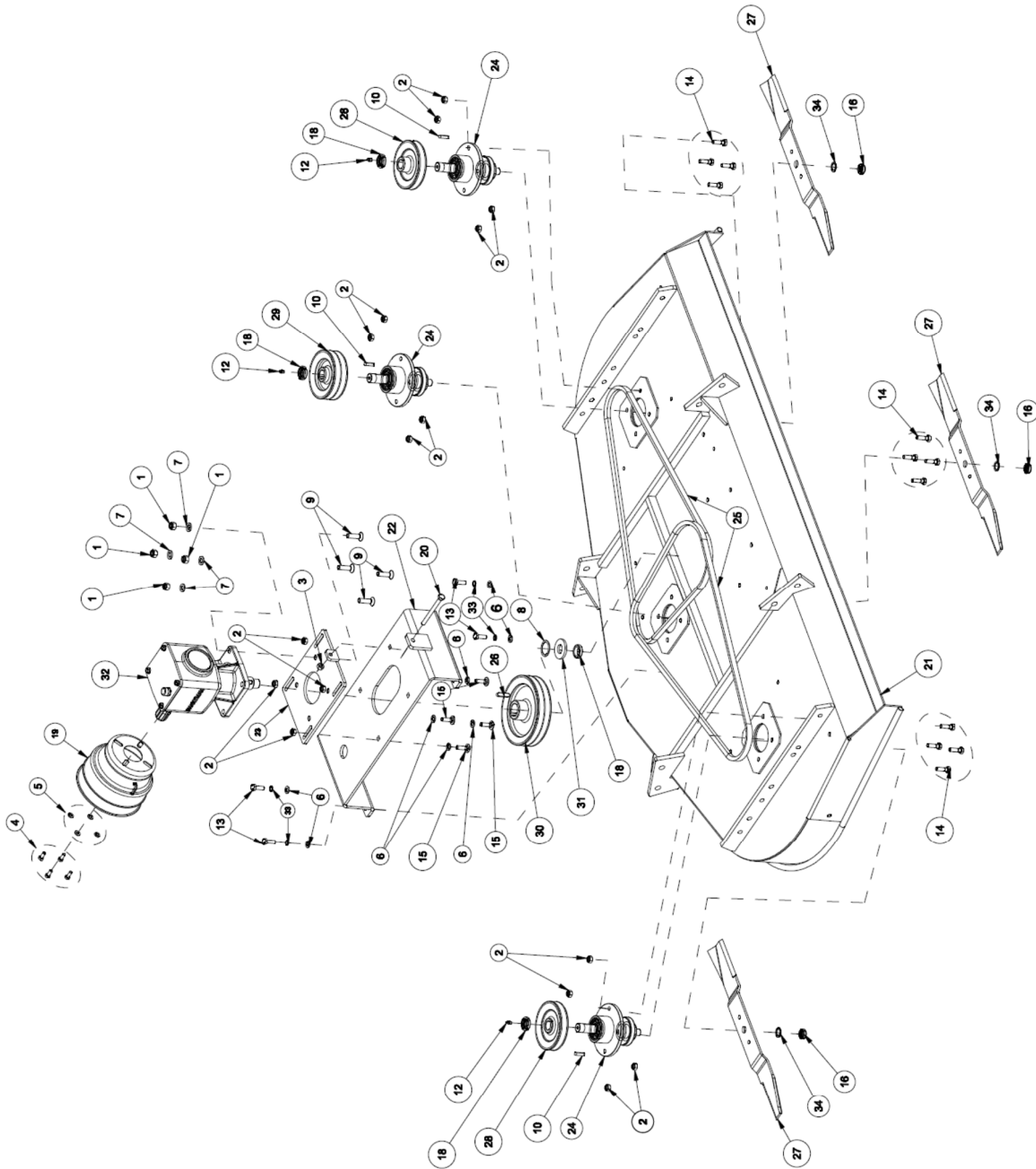

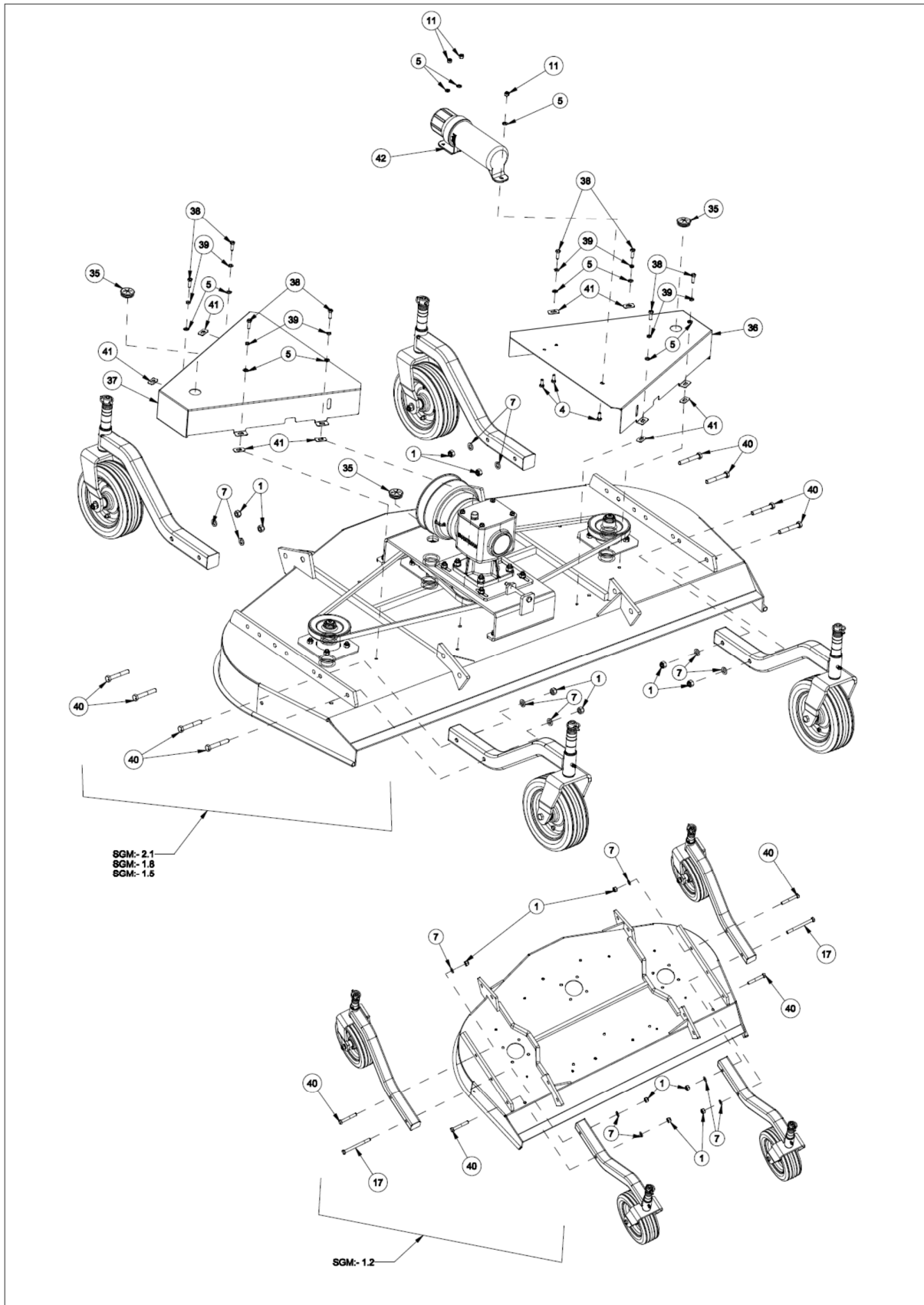

**SGM SERIES GROOMING MOWER - SPARE PARTS
TABLE_1 - KIT FRAME ASSEMBLY**

Sr No.	MANUAL NO.	PART NAME	REMARK	QTY.
1	1209	NYLOCK NUT M12 X 1.75 (DIN-982)	SGM:- 1.8	12
			SGM:- 1.5	
			SGM:- 2.1	
			SGM:- 1.2	10
2	1298	NYLOCK NUT M10X1.50 (DIN-982)		16
3	1299	HEX NUT M10X1.50(IS 1363)(8)(ZP)		1
4	8040	HEX BOLT M8X1.25X20(IS1364-2)(8.8)(ZP)		7
5	8064	PLAIN WASHER 8MM (BS-4320)		15
6	8078	PLAIN WASHER 10MM (BS-4320)		8
7	8126	PLAIN WASHER 12MM (BS-4320)	SGM:- 1.8	12
			SGM:- 1.5	
			SGM:- 2.1	
			SGM:- 1.2	10
8	1425	SIMS (DIA 45 X 35)(1.0MM)		1
9	2607	CSK BOLT M12 X 1.75 X 45		4
10	18168	KEY 8 X 7 X 32		3
11	1297	NYLOCK NUT M8X1.25 (DIN-982)		3
12	6559	GREASE NIPPLE M8 X 1		3
13	3340	HEX BOLT M10 X 1.50 X 30 DIN933 (8.8)(ZP)	SGM:- 1.8	4
			SGM:- 2.1	
			SGM:- 1.5	16
			SGM:- 1.2	
14	3345	HEX BOLT M10 X 1.50 X 35 DIN931 (8.8)(ZP)	SGM:- 1.8	12
			SGM:- 2.1	
15	25745	ROUND HEAD SQ. NECK BOLT M10 X 1.5 X 35		4
16	30736461	NYLOCK NUT M18 X 1.5 L=10		3
17	33037	HEX BOLT M12X1.75X135(HT)(8.8)DIN931	SGM:- 1.2	2
18	33006	GUK SELF LOCKING NUT M25X1.5		4
19	17788	PTO SHAFT GUARD PLASTIC		1
20	33011	HEX BOLT M10 X 1.50 X 115(FT)(8.8)DIN933	SGM:- 2.1	1
			SGM:- 1.8	
	33108	HEX BOLT M10X1.50X90(DIN933)(8.8)(ZP)	SGM:- 1.5	
	33102	HEX BOLT M10X1.50X75(DIN933)(8.8)(ZP)	SGM:- 1.2	
21	33012	FRAME WELDMENT (SGM-2.1M)		1
	33013	FRAME WELDMENT (SGM-1.2M)		
	33014	FRAME WELDMENT (SGM-1.5M)		
	33015	FRAME WELDMENT (SGM-1.8M)		
22	33019	GEARBOX SUPPORT WELDMENT (SGM-1.8M)		1
	33016	GEARBOX SUPPORT WELDMENT (SGM-2.1M)		
	33017	GEARBOX SUPPORT WELDMENT (SGM-1.2M)		
	33018	GEARBOX SUPPORT WELDMENT (SGM-1.5M)		
23	33020	GEARBOX SUPPORT PLATE (SGM)		1
24	33043	SPINDLE ASSEMBLY (6206 BEARINGS) (SGM)		3

25	33110	SET OF SPB BELT LD=2340 (2 NOS)(SGM 2.1)	SGM:- 2.1	1
	33051	SET OF SPB BELT LD=1500(2 NOS)(SGM 1.2)	SGM:- 1.2	
	33052	SET OF SPB BELT LD=1750(2 NOS)(SGM 1.5)	SGM:- 1.5	
	33111	SET OF SPB BELT LD=1950(2 NOS)(SGM 1.8)	SGM:- 1.8	
26	33054	PARALLEL KEY 10 X 8 X 40		1
27	33057	BLADE, MOWER 60 X 6 X L-616 (SGM-1.8M)		3
	33055	BLADE, MOWER 60 X 6 X L-424 (SGM-1.2M)		
	33056	BLADE, MOWER 60 X 6 X L-515.5 (SGM-1.5M)		
	33010	BLADE, MOWER 60 X 8 X L-730 (SGM-2.1M)		
28	33059	SPB TYPE PULLEY PCD=130, 1 GROOVE (SGM)	SGM:- 1.8	2
			SGM:- 1.5	
	33058	SPB TYPE PULLEY PCD=110, 1 GROOVE (SGM)	SGM:- 1.2	
33002	SPB TYPE PULLEY PCD=160, 1 GROOVE (SGM)	SGM:- 2.1		
29	33003	SPB TYPE PULLEY PCD=160, 2 GROOVE (SGM)	SGM:- 2.1	1
	33060	SPB TYPE PULLEY PCD=110, 2 GROOVE (SGM)	SGM:- 1.2	
	33061	SPB TYPE PULLEY PCD=130, 2 GROOVE (SGM)	SGM:- 1.8	
SGM:- 1.5				
30	33004	SPB TYPE PULLEY PCD=212, 2 GROOVE (SGM)	SGM:- 2.1	1
	33062	SPB TYPE PULLEY PCD=225, 2 GROOVE (SGM)	SGM:- 1.5	
			SGM:- 1.2	
33063	SPB TYPE PULLEY PCD=190, 2 GROOVE (SGM)	SGM:- 1.8		
31	33079	WASHER, DRIVING PULLEY 25X56X6 (SGM)		1
32	33085	GEAR BOX ASSEMBLY(SGM)		1
33	33099	WASHER SCHNNOR M10 (SGM)		4
34	33100	WASHER SCHNNOR M18 (SGM)		3
35	33021	ZERK CAP (SGM)		3
36	33086	BELT COVER AND ROD ASSEMBLY RH-(SGM-2.1)		1
	33088	BELT COVER AND ROD ASSEMBLY RH-(SGM-1.2)		
	33090	BELT COVER AND ROD ASSEMBLY RH-(SGM-1.5)		
	33092	BELT COVER AND ROD ASSEMBLY RH-(SGM-1.8)		
37	33087	BELT COVER AND ROD ASSEMBLY LH-(SGM-2.1)		1
	33089	BELT COVER AND ROD ASSEMBLY LH-(SGM-1.2)		
	33091	BELT COVER AND ROD ASSEMBLY LH-(SGM-1.5)		
	33093	BELT COVER AND ROD ASSEMBLY LH-(SGM-1.8)		
38	8171	HEX BOLT M8X1.25X25(IS1364-2)(8.8)(ZP)		8
39	1303	SPRING WASHER 8mm		8
40	33103	HEX BOLT M12 X 1.75 X 80(HT)(8.8)DIN931	SGM:- 1.8	8
			SGM:- 1.5	
			SGM:- 2.1	
			SGM:- 1.2	
41	33101	GASKET, BELT COVER (SGM)		8
42	1616	CONTAINER FOR MANUAL		1

SGM SERIES GROOMING MOWERS - SPARE PARTS

TABLE_2 - GEAR BOX ASSEMBLY

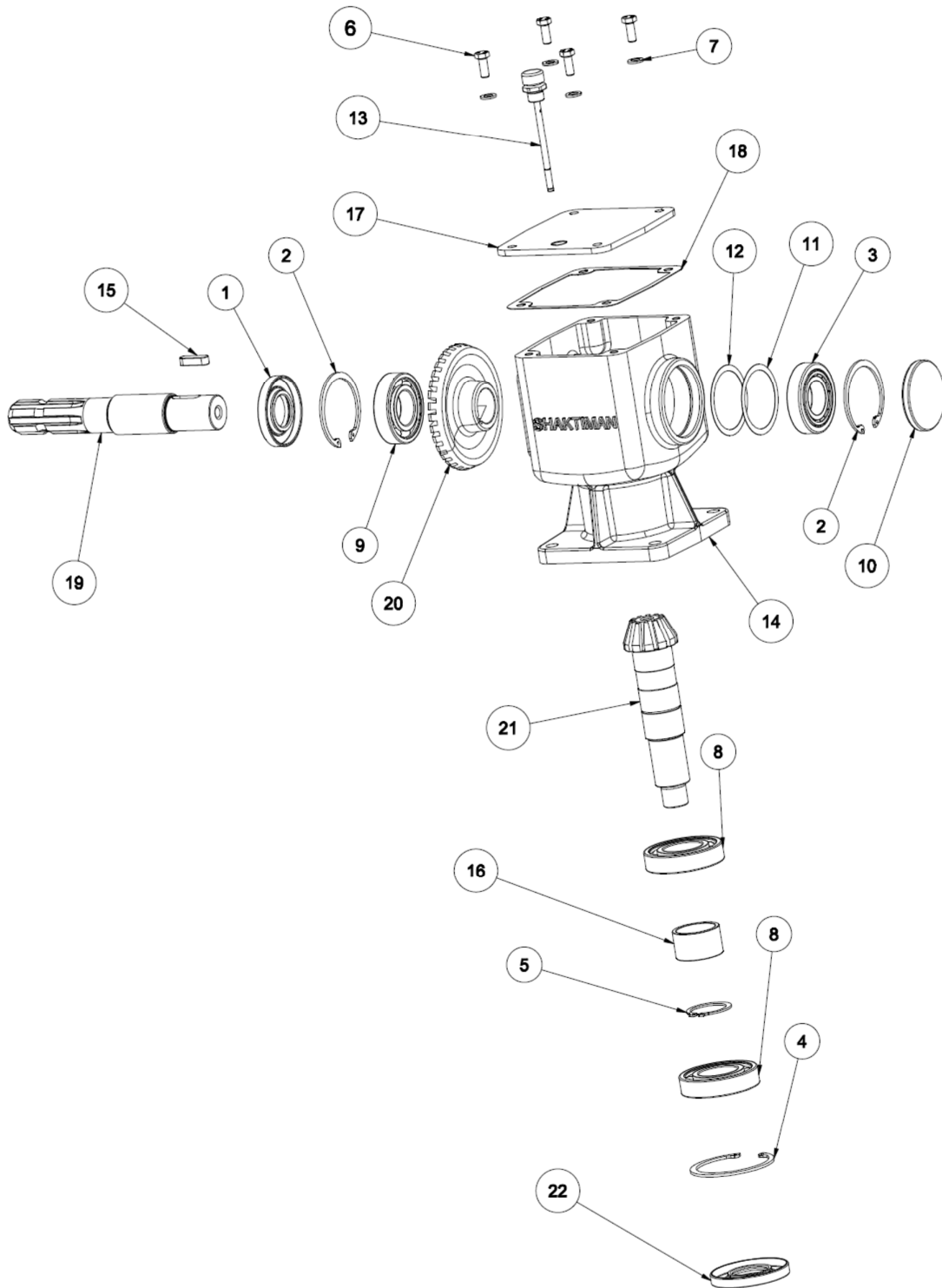

SGM SERIES GROOMING MOWER - SPARE PARTS**TABLE_2 - GEARBOX ASSEMBLY**

Sr No.	MANUAL NO.	PART NAME	QTY.
1	1001	OIL SEAL 35 X 72 X 10	1
2	1002	CIRCLIP INTERNAL 72mm	2
3	1003	BEARING 30207	1
4	1130	CIRCLIP INTERNAL 80mm	1
5	8027	CIRCLIP EXTERNAL 40mm	1
6	8040	HEX BOLT M8X1.25X20(IS1364-2)(8.8)(ZP)	4
7	8064	PLAIN WASHER 8MM (BS-4320)	4
8	7033	BEARING 6208	2
9	10143	BEARING 6207	1
10	14119	OIL SEAL 72X8	1
11	4652	SIMS (DIA 72 X 60)(0.20mm)	1
12	4653	SIMS (DIA 72 X 60)(0.30mm)	1
13	14316	DIPSTICK 106MM (M16 X 1.5) (1MLSR202)	1
14	33005	GEAR BOX HOUSING (SGM)	1
15	33050	PARALLEL KEY 10 X 8 X 32	1
16	33078	SPACER, PINION 40X48X28 (SGM)	1
17	33080	GEARBOX COVER (SGM)	1
18	33081	GASKET, GEARBOX COVER (SGM)	1
19	33082	INPUT SHAFT, (SGM)	1
20	33083	BEVEL GEAR Z-34 TEETH (SGM)	1
21	33084	BEVEL PINION SHAFT 12 TEETH (SGM)	1
22	35005	OIL SEAL 40 X 80 X 10 (MAX)	1

SGM GROOMING MOWERS - SPARE PARTS
TABLE_3 - SPINDLE ASSEMBLY (6205 / 6206)

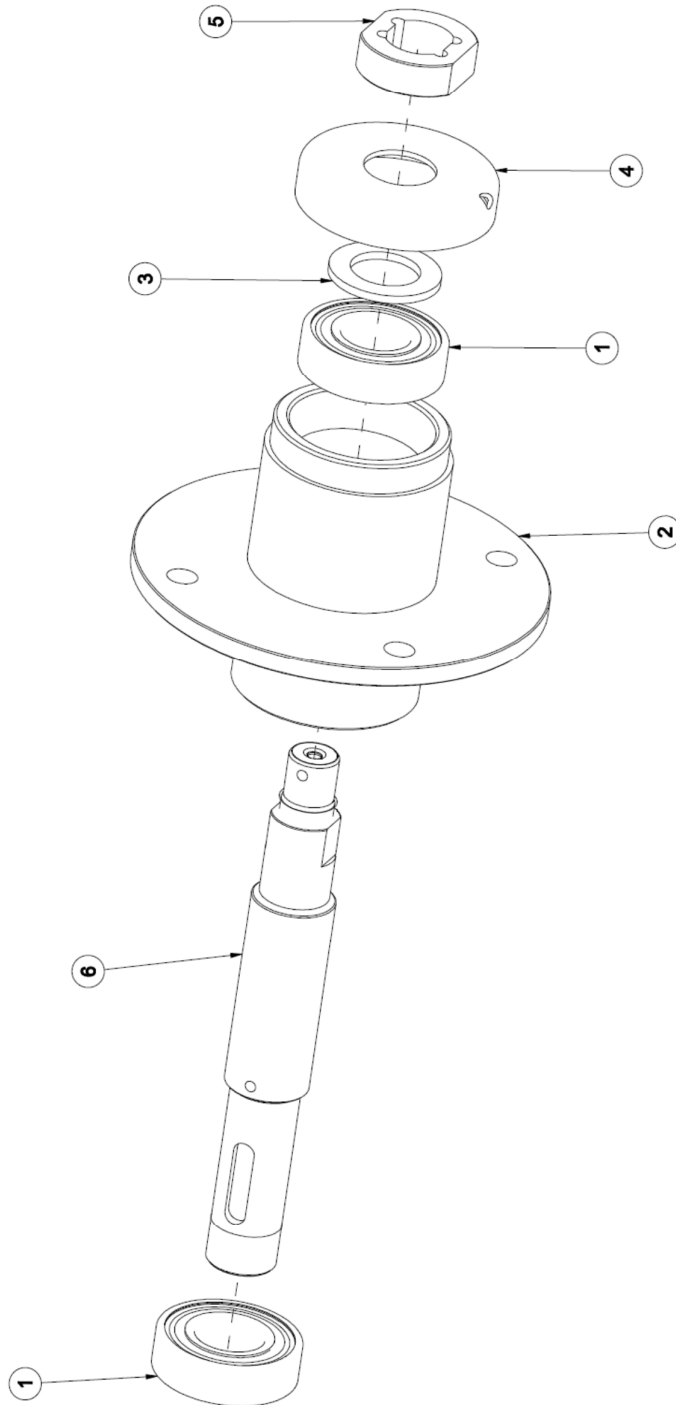

**SGM SERIES GROOMING MOWER - SPARE PARTS
TABLE_3 - SPINDLE ASSEMBLY (6205 / 6206)**

Sr No.	MANUAL NO.	PART NAME	QTY.
1	8105	BEARING 6205 2RS	2
	12210	BEARING 6206 2RS	2
2	33044	SPINDLE (BEARINGS 6205) (SGM)	1
	33038	SPINDLE (BEARINGS 6206) (SGM)	1
3	33045	SPACER WASHER 25X40X3 (6205) (SGM)	1
	33040	SPACER WASHER (30X60X5) (6206) (SGM)	1
4	33046	DUST PROTECTION COVER (6205) (SGM)	1
	33041	DUST PROTECTION COVER (6206) (SGM)	1
5	33047	BUSHING, BLADE TIGHTENING (6205) (SGM)	1
	33042	BUSHING, BLADE TIGHTENING (6206) (SGM)	1
6	33048	SHAFT, SPINDLE - (BEARINGS 6205) (SGM)	1
	33039	SHAFT, SPINDLE - (6206 BEARINGS) (SGM)	1

SGM SERIES GROOMING MOWERS - SPARE PARTS
TABLE_4 - TUBE ASSEMBLY TYRE

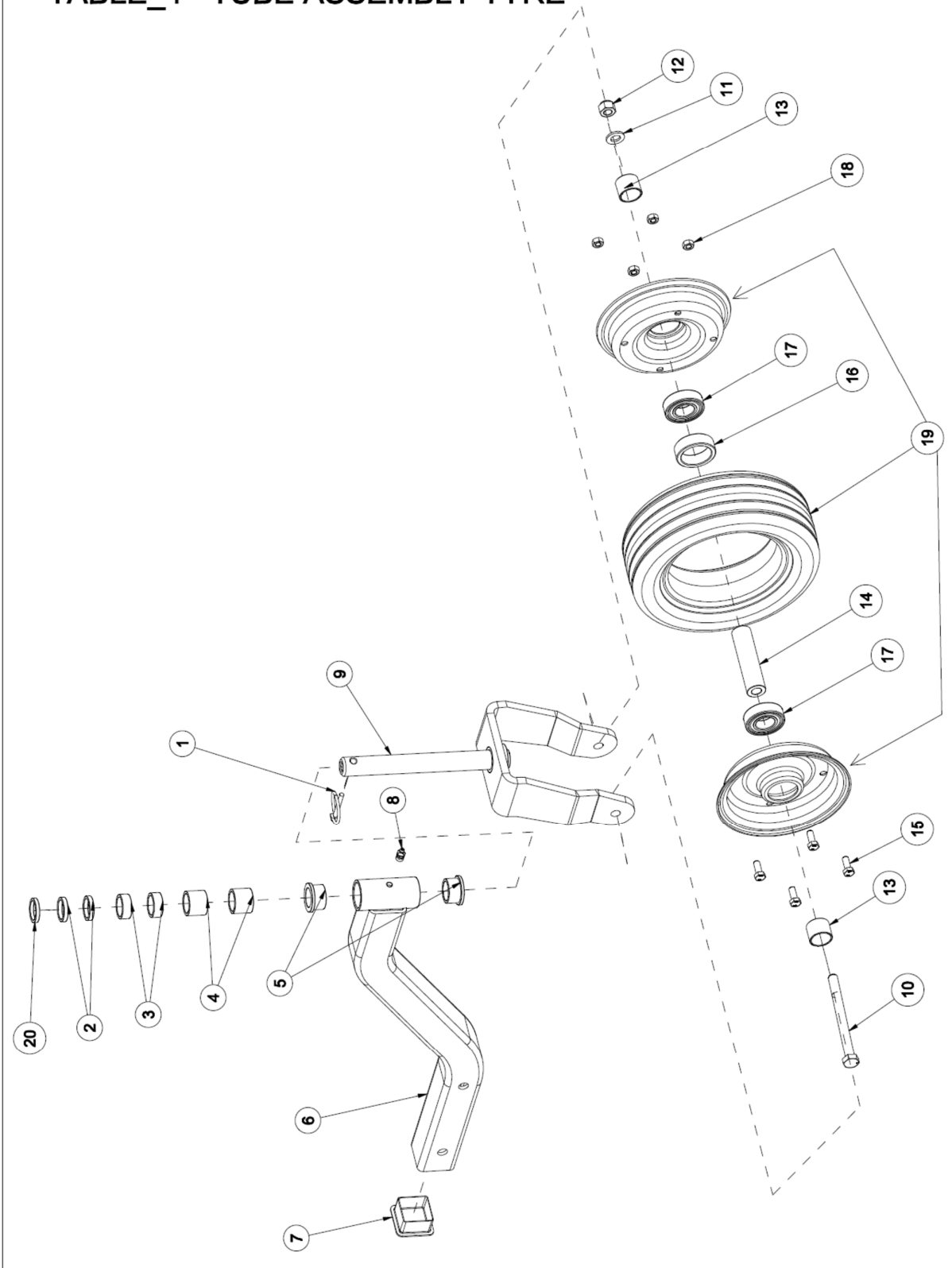

SGM SERIES GROOMING MOWERS - SPARE PARTS
TABLE_4 - TUBE ASSEMBLY TYRE

Sr. No.	MANUAL NO.	PART NAME	QTY.
1	8204	LINCH PIN SMALL (CHO)	1
2	33073	SPACER 25X32X6 (SGM)	2
3	33074	SPACER 25X32X12.5 (SGM)	2
4	33075	SPACER 25X32X25 (SGM)	2
5	33007	PLASTIC BEARING MFM-2532-20	2
6	33064	WHEEL HALF-ARM WELDMENT (SGM)	1
7	23163	SQ. PIPE PLASTIC CAP 50MM	1
8	20148	GREASE NIPPLE M8 X 1.25	1
9	33068	WHEEL YOKE REINF. WELD. (10MM) (SGM)	1
10	33037	HEX BOLT M12X1.75X135(DIN931)(8.8)(ZP)	1
11	8126	PLAIN WASHER 12MM (BS-4320)	1
12	1209	NYLOCK NUT M12X1.75 (DIN-982)	1
13	33070	SPACER, SOLID TYRE(30X26X23.5) (SGM)	2
14	33069	WHEEL MOUNTING PIPE (SGM)	1
15	8040	HEX BOLT M8X1.25X20(IS1364-2)(8.8)(ZP)	4
16	33065	SPACER 52X40X17 (SGM)	1
17	8105	BEARING 6205 2RS	2
18	8181	HEX NUT M8X1.25(IS 1363)(8)(ZP)	4
19	33008	SOLID TYRE 10"X4" (SGM)	1
20	33116	SPACER 25X32X5 (SGM)	1

SGM SERIES GROOMING MOOWERS - SPARE PARTS TABLE_5 - KIT 3- POINT ATTACHMENT

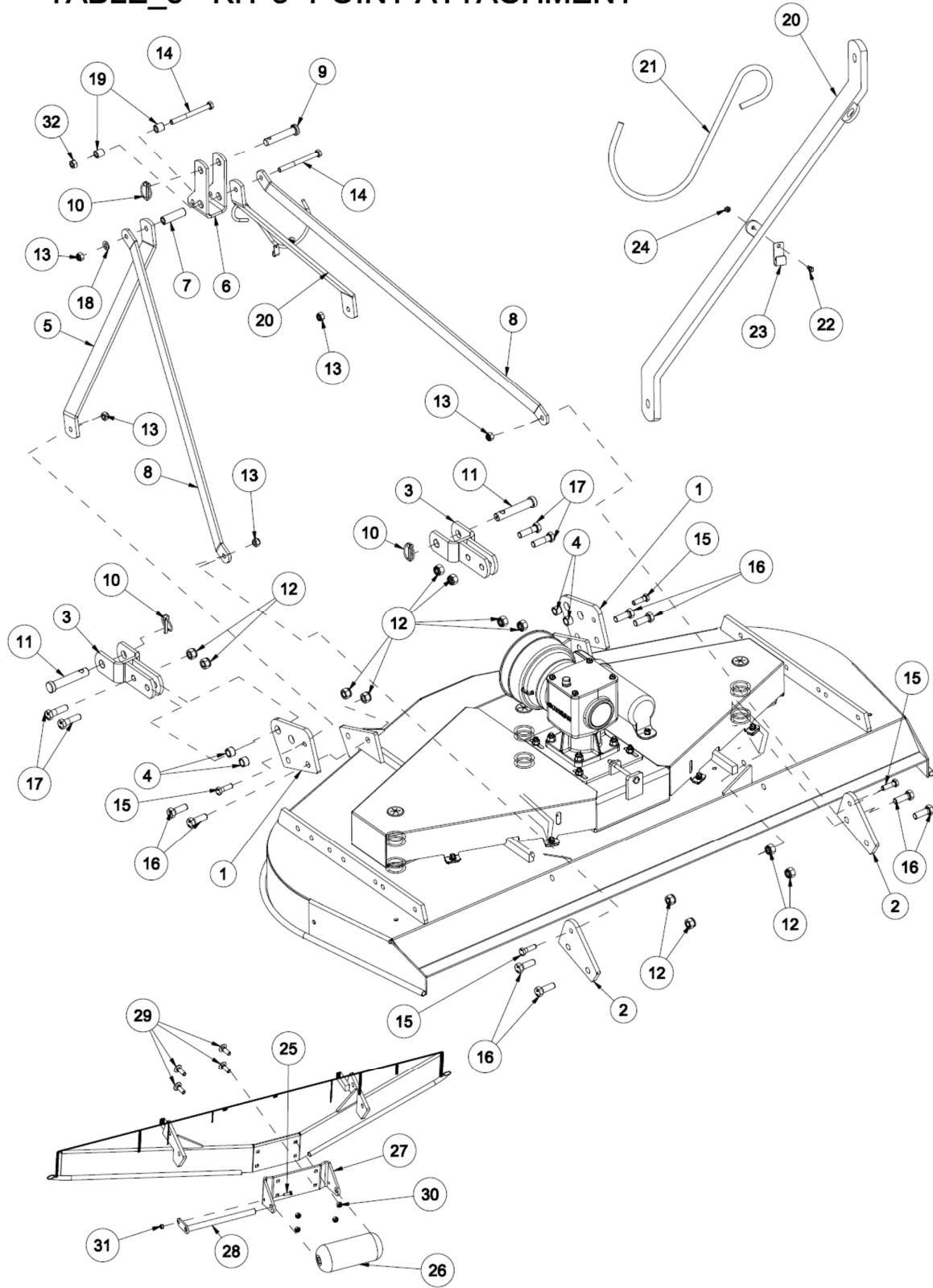

SGM SERIES GROOMING MOOWERS - SPARE PARTS

TABLE_5 - KIT 3- POINT ATTACHMENT

Sr.No.	Manual Code	PART NAME	Qty.
1	33025	CONNECTION PLATE, FRONT (SGM)	2
2	33026	CONNECTION PLATE, REAR (SGM)	2
3	33035	WELDED YOKE,LOWER HITCH (SGM)	2
4	33027	BUSHING, LOWER HITCH (SGM)	4
5	33028	TOP HITCH SUPPORT (LH) (SGM)	1
6	33029	COUPLING, UPPER 3-POINT HITCH (SGM)	1
7	33030	SPACER, UPPER 3 POINT HITCH (SGM)	1
8	33031	TOP HITCH ARM (SGM-2.1M)	2
	33032	TOP HITCH ARM, (SGM-1.2M)	
	33033	TOP HITCH ARM (SGM-1.5M)	
	33034	TOP HITCH ARM (SGM-1.8M)	
9	33036	PIN, TOP HITCH (CATEGORY I) (SGM)	1
10	1218	LINCH PIN	3
11	1216	HITCH PIN BOTTOM CAT-I (DIA-22 X 129)	2
12	1231	NYLOCK NUT M16X2.0 (DIN-982)	12
13	1209	NYLOCK NUT M12X1.75 (DIN-982)	5
14	33104	HEX BOLT M12X1.75X130(DIN931)(8.8)(ZP)	2
15	3343	HEX BOLT M12X1.75X40(DIN931)(8.8)(ZP)	4
16	8196	HEX BOLT M16X2.00X45(IS1364-1)(8.8)(ZP)	8
17	18446	HEX BOLT M16X2.00X55(IS1364-1)(8.8)(ZP)	4
18	8126	PLAIN WASHER 12MM (BS-4320)	1
19	33115	BUSH 21X13X22 (SGM)	2
20	33117	TOP HITCH SUPPORT WELDMENT (SGM)	1
21	14340	DRIVELINE HOOK 250MM	1
22	23029	HEX BOLT M4X0.75X10(IS1364-2)(8.8)(ZP)	1
23	23147	PLATE,HOOK HOLDING (JUMBO)	1
24	23028	HEX NUT M4X0.75(IS 1363)(8)(ZP)	1
25	8171	HEX BOLT M8X1.25X25(IS1364-2)(8.8)(ZP)	1
26	33024	FRONT ROLLER, AIR WHEELS (SGM)	1
27	33023	BRACKET, FRONT ROLLER (SGM)	1
28	33022	ROD WELDMENT, FRONT ROLLER (SGM)	1
29	8174	RO HD SQ NECK BOLT M10 X 1.5 X 30 FT-8.8	4
30	1298	NYLOCK NUT M10X1.50 (DIN-982)	4
31	1297	NYLOCK NUT M8X1.25 (DIN-982)	1
32	1301	HEX NUT M12X1.75(IS 1363)(8)(ZP)	1

SGM GROOMING MOWERS - SPARE PARTS TABLE_6 - MULCHING KIT ASSEMBLY

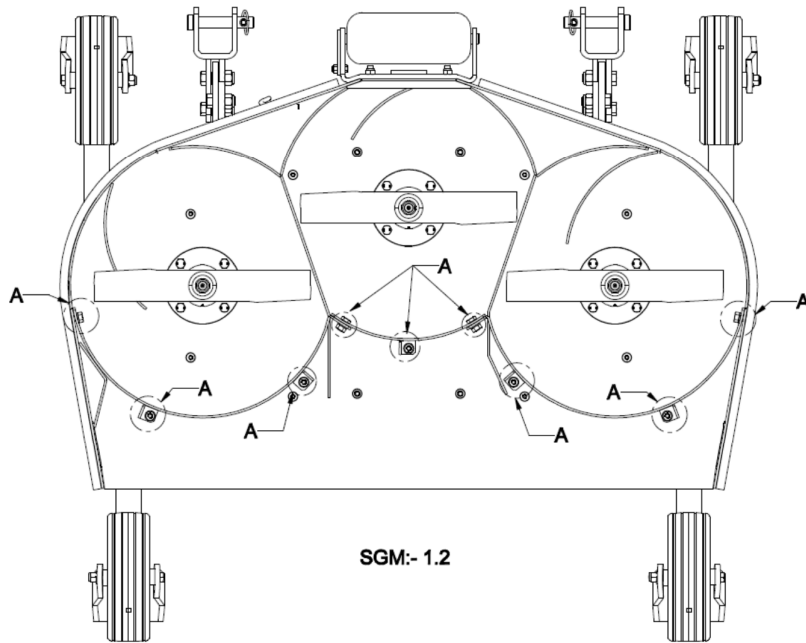
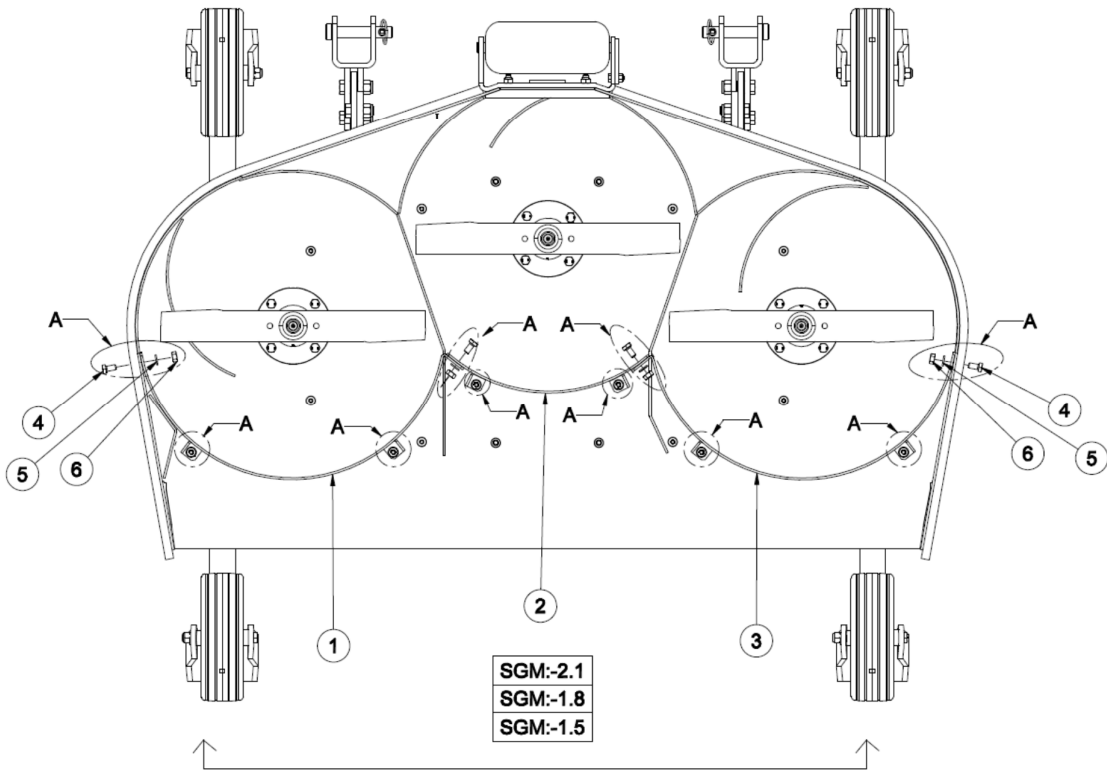

MULCHING KIT

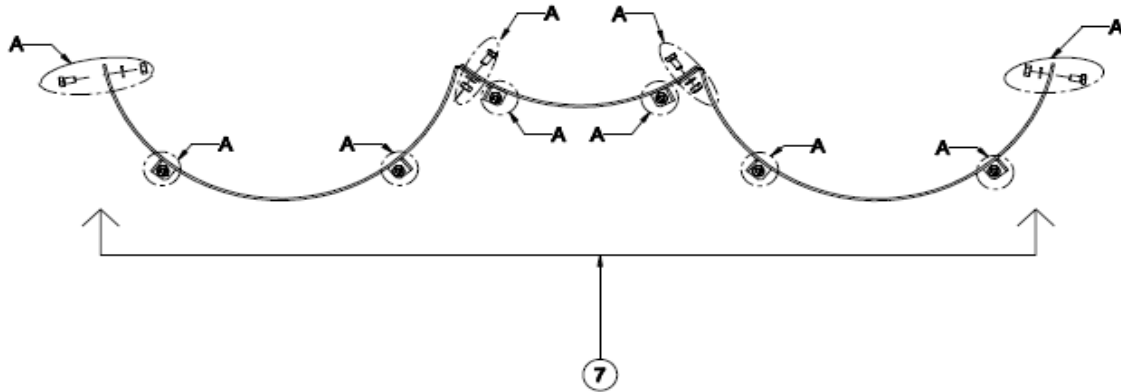

SGM SERIES GROOMING MOOWERS - SPARE PARTS				
TABLE_6 - MULCHING KIT ASSEMBLY				
Sr.No.	MANUAL NO.	PART NAME	REMARK	QTY.
1	33120	CONTAINING PLATE WELDMENT LH (SGM-1.2M)	SGM:- 1.2	1
	33123	CONTAINING PLATE WELDMENT LH (SGM-1.5M)	SGM:- 1.5	
	33126	CONTAINING PLATE WELDMENT LH (SGM-1.8M)	SGM:- 1.8	
	33129	CONTAINING PLATE WELDMENT LH (SGM-2.1M)	SGM:- 2.1	
2	33119	CONTAINING PLATE WELD. MIDDLE (SGM-1.2M)	SGM:- 1.2	1
	33122	CONTAINING PLATE WELD. MIDDLE (SGM-1.5M)	SGM:- 1.5	
	33125	CONTAINING PLATE WELD. MIDDLE (SGM-1.8M)	SGM:- 1.8	
	33128	CONTAINING PLATE WELD. MIDDLE (SGM-2.1M)	SGM:- 2.1	
3	33118	CONTAINING PLATE WELDMENT RH (SGM-1.2M)	SGM:- 1.2	1
	33121	CONTAINING PLATE WELDMENT RH (SGM-1.5M)	SGM:- 1.5	
	33124	CONTAINING PLATE WELDMENT RH (SGM-1.8M)	SGM:- 1.8	
	33127	CONTAINING PLATE WELDMENT RH (SGM-2.1M)	SGM:- 2.1	
4	17276	HEX BOLT M10 X 1.50 X 20 DIN933 (8.8)(ZP)	SGM:- 1.2	9
			SGM:- 1.5	10
			SGM:- 1.8	10
			SGM:- 2.1	10
5	1299	Hex Nut M10X1.50(IS 1363)(8)(ZP)	SGM:- 1.2	9
			SGM:- 1.5	10
			SGM:- 1.8	10
			SGM:- 2.1	10
6	8078	PLAIN WASHER 10MM (BS-4320)	SGM:- 1.2	9
			SGM:- 1.5	10
			SGM:- 1.8	10
			SGM:- 2.1	10
7	33130	MULCHING KIT ASSEMBLY (SGM-1.2M)	SGM:- 1.2	1

33131	MULCHING KIT ASSEMBLY (SGM-1.5M)	SGM:- 1.5
33132	MULCHING KIT ASSEMBLY (SGM-1.8M)	SGM:- 1.8
33133	MULCHING KIT ASSEMBLY (SGM-2.1M)	SGM:- 2.1

FARM-MAXX

Unifarm Machinery Corporation

P.O. CAGE 38

4608 Lely Road

Wilson - NC 27893

North Carolina NC 27893

USA